

Apollo Vehicle Safety

Automotive Research and Consultancy



PROJECT REPORT RR2016_005

Energy Absorbing Front Underrun Protection for Trucks

Developing a test procedure

By Iain Knight

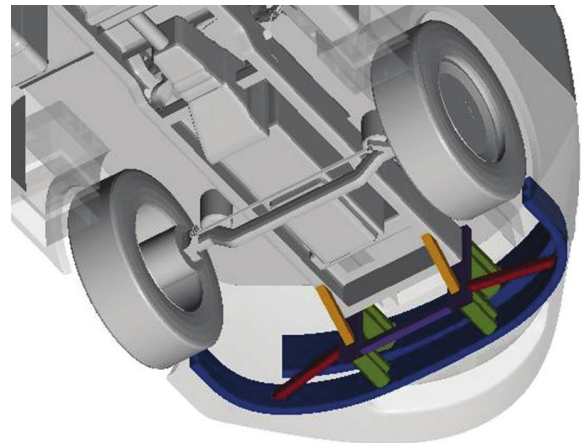

Prepared for: Transport & Environment, Brussels
Project Ref: HGV Safety & Aerodynamics

Disclaimer

This report has been produced by Apollo Vehicle Safety under a contract with Transport & Environment. Any views expressed in this report are not necessarily those of Transport & Environment.

The information contained herein is the property of Apollo Vehicle Safety Limited and does not necessarily reflect the views or policies of the customer for whom this report was prepared. Whilst every effort has been made to ensure that the matter presented in this report is relevant, accurate and up-to-date, Apollo Vehicle Safety Limited cannot accept any liability for any error or omission, or reliance on part or all of the content in another context.

Contents

Executive Summary	1
1 Introduction	3
2 Methodology and limitations	4
3 The current situation	5
4 Defining the opportunity for change	10
5 Parameters for evaluation and control	12
5.1 Representation of real world collisions	12
5.2 Probability of car occupant injury	14
5.3 Structural interaction	16
5.3.1 Vertical alignment	17
5.3.2 Horizontal alignment	18
5.3.3 Stiffness and deformation forces	22
5.3.4 Interaction with other components	24
5.4 Energy absorption	25
5.5 Prevention of underrun	27
5.6 Repeatability and reproducibility	29
6 Candidate Assessment Techniques	30
6.1 Design Requirements	30
6.2 Quasi static tests	30
6.3 Dynamic impact tests	31
6.3.1 Fixed or movable impactor	32
6.3.2 Full truck or FUP sub-assembly	32
6.3.3 Rigid impactor	32
6.3.4 Mobile Deformable Barrier (AE-MDB)	33
6.3.5 Progressive deformable barrier	36
6.3.6 Passenger car	40
6.4 Numerical simulation	40
7 Analysis	42
7.1 Defining the options	43
7.1.1 Quasi-Static assessment	44
7.1.2 MPDB based assessment	46
7.1.3 Purpose defined barrier	47
7.2 Potential benefits	48
7.3 Proposed validation programme.	48
8 Conclusions	50
9 References	51

Executive Summary

In the European Union in 2013 around 4,000 people were killed in accidents involving heavy goods vehicles (HGVs) in excess of 3.5 tonnes. Just under half of those killed were car occupants. Head on crashes between cars and trucks are a very severe type of crash involving high relative speeds (50% >130 km/h) and a high risk of fatality (10% of all such casualties are killed). One of the problems in such collisions is the crash compatibility of the vehicles; trucks are heavier, their main structures are stiffer and are positioned higher from the ground than for passenger cars. Front underrun protection (FUP) was introduced to try to reduce the risks of these crashes. Most current devices are built for compliance with existing regulation and few offer as standard an integrated energy absorbing system.

However, there is evidence to suggest that current devices are not working as well as was expected. FUP would not be expected to reduce the chances of getting involved in a crash but would be expected to reduce the chance of being killed if you were involved. Data from GB shows that the frequency of relevant crashes has declined substantially during the time period where FUP has been introduced. However, the proportion of the casualties involved that were killed or seriously injured has, at best, remained approximately constant and may even be increasing. There is also physical evidence to show that in practice, the structural interaction between vehicles can in some cases remain poor, despite the presence of FUP. Although the structural interaction and energy absorption characteristics cannot be proven to be a direct cause of the absence of expected effect, it offers substantial scope for reasonable improvements to be made.

Directive 2015/719 allows the length of HGVs to be increased in defined circumstances and this provides an opportunity to redesign front underrun protection to improve performance in both those areas. This review has identified the desirable properties for front underrun protection on extended length trucks and has assessed the ability of different test methods to ensure the devices do possess those properties.

Good structural interaction is a pre-requisite of effective energy absorption and effective casualty reduction. The proposed test methods would ensure a substantial improvement in that interaction by better controlling the vertical alignment of vehicle structures, increasing the area of stiff structure and reducing the chances of other vehicle componentry forming undesirable alternative load paths during an impact.

The benefits of energy absorption will depend on the length increase chosen by the vehicle manufacturer. A length increase of 400-600mm could make crashes with closing speed of up to around 75km/h to 100 km/h survivable, depending on a range of variables including the relative masses of vehicles, and the stiffness characteristics selected. If this performance level was standard fitment in the fleet then it could prevent 40 – 134 deaths and 675 to 900 serious injuries in the EU, valued at between around €220million and €420 million.

Three feasible policy options were identified for the implementation of a test procedure to define these new performance levels. They involve combining design restrictive criteria with assessments based on:

- Quasi-static testing
- A Mobile Progressive Deformable Barrier (MPDB) test
- A mobile test with a purpose designed barrier face

The proposals are soundly backed by theory and evidence adapted from tests on standard length vehicles. However, a substantial validation test programme would be required to prove the effectiveness of the tests in promoting good real world performance, to refine the selection of limit values and to inform cost benefit analyses used to help select the final procedure.

An initial, semi-objective, scoring of the options suggests that an MPDB based approach would offer substantial safety and innovation advantages over a quasi-static based assessment but would cost considerably more and require more complex development. A purpose built barrier would only be necessary if identified risks of the PDB approach did indeed prove to be problematic when assessed with representative prototype devices.

Numerical simulation may still be acceptable for type approval as an alternative to the physical test procedures defined. However, if additional validation may be required if the dynamic tests were selected because it is a much more complex test than those structural tests that 2007/46/EC permits to be replaced by simulation.

1 Introduction

Statistics show (European Road Safety Observatory, 2015) that in the European Union in 2013 around 4,000 people were killed in accidents involving heavy goods vehicles (HGVs) in excess of 3.5 tonnes. Just under half of those killed were car occupants. One of the problems in such collisions is the crash compatibility of the vehicles; trucks are heavier, their main structures are stiffer and are positioned higher from the ground than for passenger cars. Front underrun protection places stiff structures on trucks in a position intended to interact with the energy absorbing structures of cars. It is mandatory for most HGVs in the EU with the technical requirements prescribed by Regulation 93. However, the potential of HGVs to absorb energy in a crash with a passenger car has remained limited by the amount of deformation space available between the front of the vehicle and the front axle. Directive (EU) 2015/719 offers the potential to remove that limitation by allowing trucks to be longer than the maximum currently permitted provided that it does not increase the load space and it does improve safety and environmental performance.

One of the factors required to show improved safety performance is an improvement to the protection of car occupants in collision with the front of an HGV and this improvement must be demonstrated through the type approval system.

There are currently no regulatory instruments that can be used to demonstrate that approval. Transport & Environment therefore commissioned Apollo Vehicle Safety to review the available evidence in order to begin the process of defining a test and evaluation procedure that would be capable of demonstrating improved performance in a type approval test.

The review was a desk-top exercise collecting evidence from existing test procedures and past research on both car-to-truck and car-to-car compatibility. However, few FUPs have been designed based on the concept of an extended length HGV and so the analysis required considerable inference based on tests with existing designs and evaluation of the properties that are beneficial for crash compatibility.

An outline was, therefore, identified of the additional physical test and experimental research that would be required to increase scientific/*/*-/ confidence in the results and to refine the limit values proposed.

This report describes the technical work in full.

2 Methodology and limitations

All of the findings of this work have been based on desk-based reviews of existing and proposed regulations and standards along with supporting scientific literature studying:

- the properties of crashes between the cars and the front of trucks,
- desirable and undesirable characteristics of under-run protection,
- the wider problems of crash compatibility between vehicles of all types,
- Test and assessment procedures intended to promote improvements in crash compatibility.

There was no standard or scientific research paper that provided a solution perfectly suited to the objectives of this work. The options proposed were, therefore, based on evidence extracted from the body of existing work and adapted to the objectives of this specific task. So, these options are well supported by general evidence and theory but are not, as yet, validated in terms of their specific suitability in the exact application intended here. Further validation work using high fidelity numerical simulations and/or physical impact tests would allow better informed selection of the correct option as well as enabling specific criteria and limit values to be fine-tuned. Increased scientific confidence would be gained that the selected test method would successfully promote casualty reduction in the real-world scenarios intended.

3 The current situation

Statistics show (European Road Safety Observatory, 2015) that in the European Union in 2013 4,021 people were killed in accidents involving heavy goods vehicles (HGVs) in excess of 3.5 tonnes. Just under half (1915, 48%) of those killed were car occupants.

A more detailed breakdown of what happens in these accidents is also not available at a European level. However, (Chislett & Robinson, 2010) showed that in Great Britain between 2006 and 2008, 35% of all the car occupant fatalities arising from collisions with HGV were involved in head-on (front to front) collisions, the accident mechanism most relevant to front underrun protection. A further 31% were involved in collisions with the front of the truck but another (side or rear) part of the car, for a grand total of 66% colliding with the front of the truck. If it were assumed that these proportions applied across the EU in 2013 then 670 car occupants would have been killed in head-on (front to front) collisions between cars and HGVs.

Information on serious injuries is not collected uniformly across Europe so equivalent figures for the number of seriously injured casualties is only available for some Member States. In GB, head on collisions between cars and 7.5 tonne trucks there is on average approximately 2.3 seriously injured car occupants for every fatality (source Stats 19). If this same definition and reporting level applied across Europe it would imply a total of around 1,500 seriously injured car occupants from head on collisions with trucks.

One of the problems in such collisions is the crash compatibility of the vehicles; trucks are heavier, their main structures are stiffer and are positioned higher from the ground than for passenger cars. Front underrun protection is intended to place stiff structures on trucks in a position intended to interact with the energy absorbing structures of cars. It is mandatory for most HGVs in the EU with the technical requirements prescribed by Regulation 93 (UNECE, 1994). The main dimensional requirements and the points at which defined test loads must be applied are summarised in Figure 1, below.

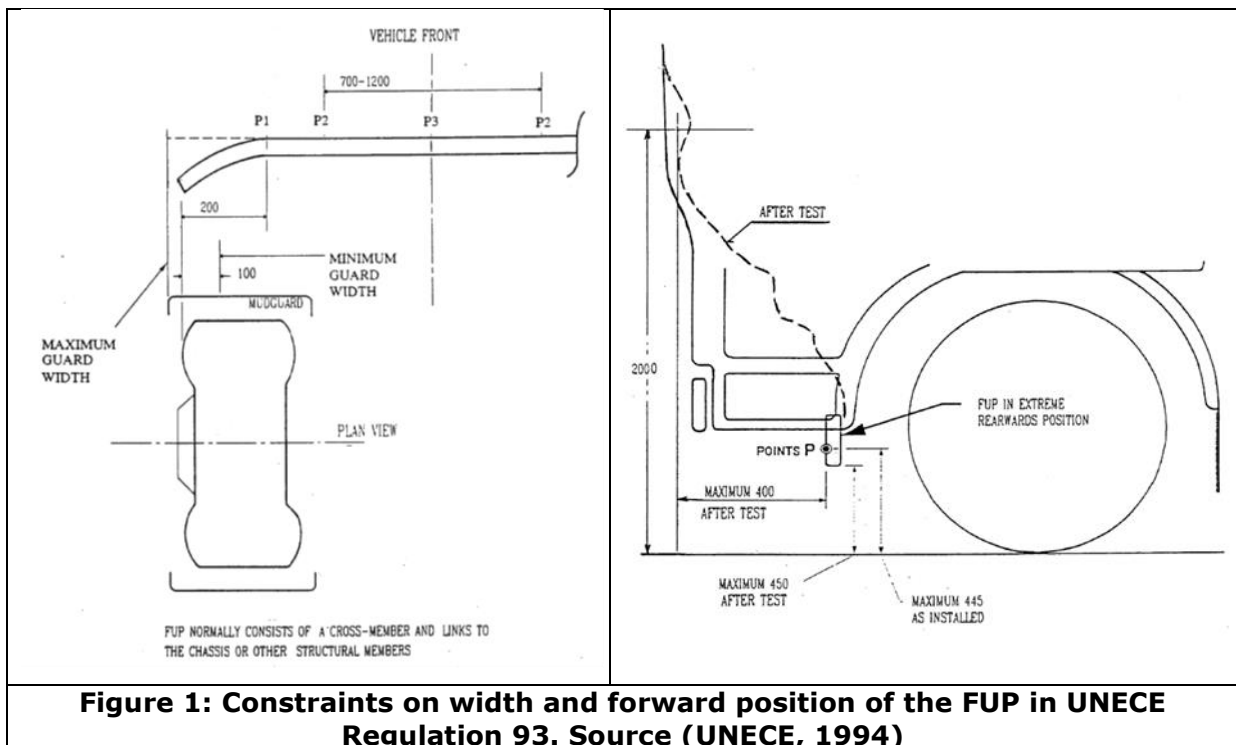

It can be seen that the Regulation embodies the concept that the front underrun protection is fitted straight across the flat front of a traditional vehicle, except for the extreme outer edges, which may be curved. It may be no more than 400mm from the ground, the cross member must be at least 120mm tall and after the test loads have been applied the initial positioning and residual deformation in combination must leave it positioned no further than 400mm rearward of the front of the vehicle. The latter limit in practice limits the chance that the chassis rails of the truck meet the windscreen or A-pillar area of the colliding car. The test loads applied are 80 kN at P1 and P3 and 160kN at P2. These are applied sequentially and not simultaneously.

The regulation is worded such that when these loads are applied, the deformation can be zero or, if initially positioned at the very front of the vehicle, it can be up to 400mm. With zero deformation then zero energy is absorbed. If point P2 deformed by 400mm with the test load applied, then 64kJ would be absorbed. Thus, the current regulation permits energy absorption but does not require it.

(Anderson, 2003) showed that most of a small sample of production FUP devices approved to R93 deformed by 50mm or less during the tests, suggesting that in practice, at the test loads prescribed, little energy was absorbed. However, the behaviour at higher test loads is not known, so it remains possible that these approved 'rigid' devices will in fact absorb energy in some higher speed crashes.

The authors are not aware of any fully rigorous post-hoc studies of the effect that Regulation 93 has had on the severity of injury in head on collisions between cars and HGVs. The expectation would be that the fitment of front underrun protection in the fleet would have increased from near zero in 2003 to a large proportion of the fleet in 2013. FUPS are intended to have the greatest effect on head on collisions. It would not be expected that FUP would affect the frequency with which crashes occur but it would be expected to reduce the proportion of those car occupants involved in such crashes that were killed or seriously injured. Analysis has been undertaken of GB crash data identifying car occupant casualties from collisions involving HGVs in excess of 7.5 tonnes GVW that occurred from 2005 to 2013. The results are shown first for all car occupants in collision with an HGV > 7.5 tonnes in terms of both frequency and injury severity.

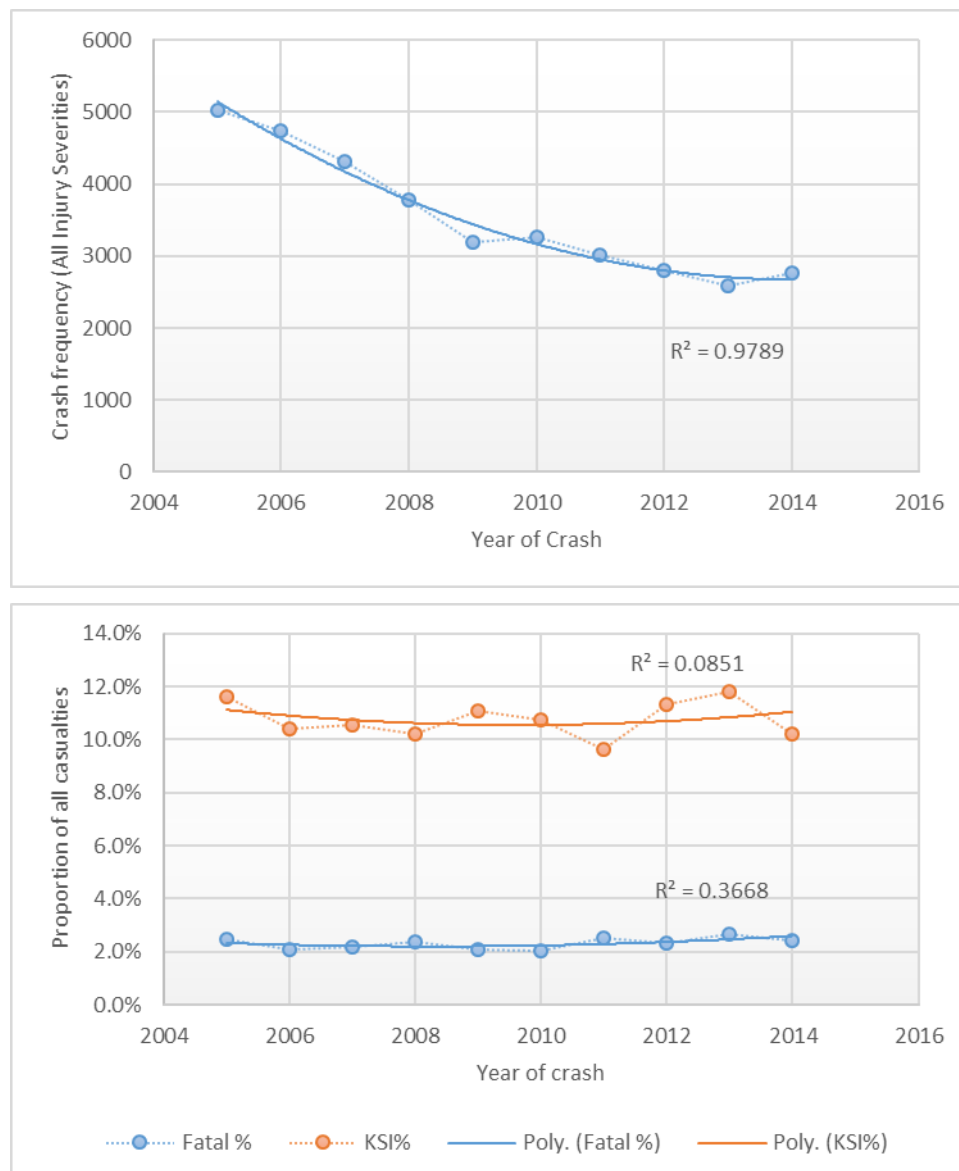

Figure 2: Frequency (top) and severity (bottom) for all car occupants injured in collision with an HGV > 7.5t. Source: GB National Accident Database (Stats 19).

It can be seen that there has been a strong reduction in the frequency of car occupant casualties in collisions with HGVs, though this has slowed in recent years. However, it can also be seen that once car occupants become involved in such a collision, the chances of being killed or seriously injured have remained about the same. The probability of severe injury in a crash depends on many factors, including the age of occupants, the speeds at which vehicles collide, the self-protection capabilities of the car (including the use of restraints by occupants), and the partner protection capabilities of the truck. The figures can also be influenced by statistical changes. For example, the reporting rate for fatal crashes always nears 100% but can be substantially lower for low severity crashes. A variation in the reporting of low severity crashes can therefore have a strong influence on the proportions measured to be killed or seriously injured. So, it can be concluded either that the changes in car self-protection or truck partner protection have not had much effect, or that other changes in the crash population, including statistical artefacts, have masked that effect.

The results if only head-on collisions are considered are shown in Figure 3, below.

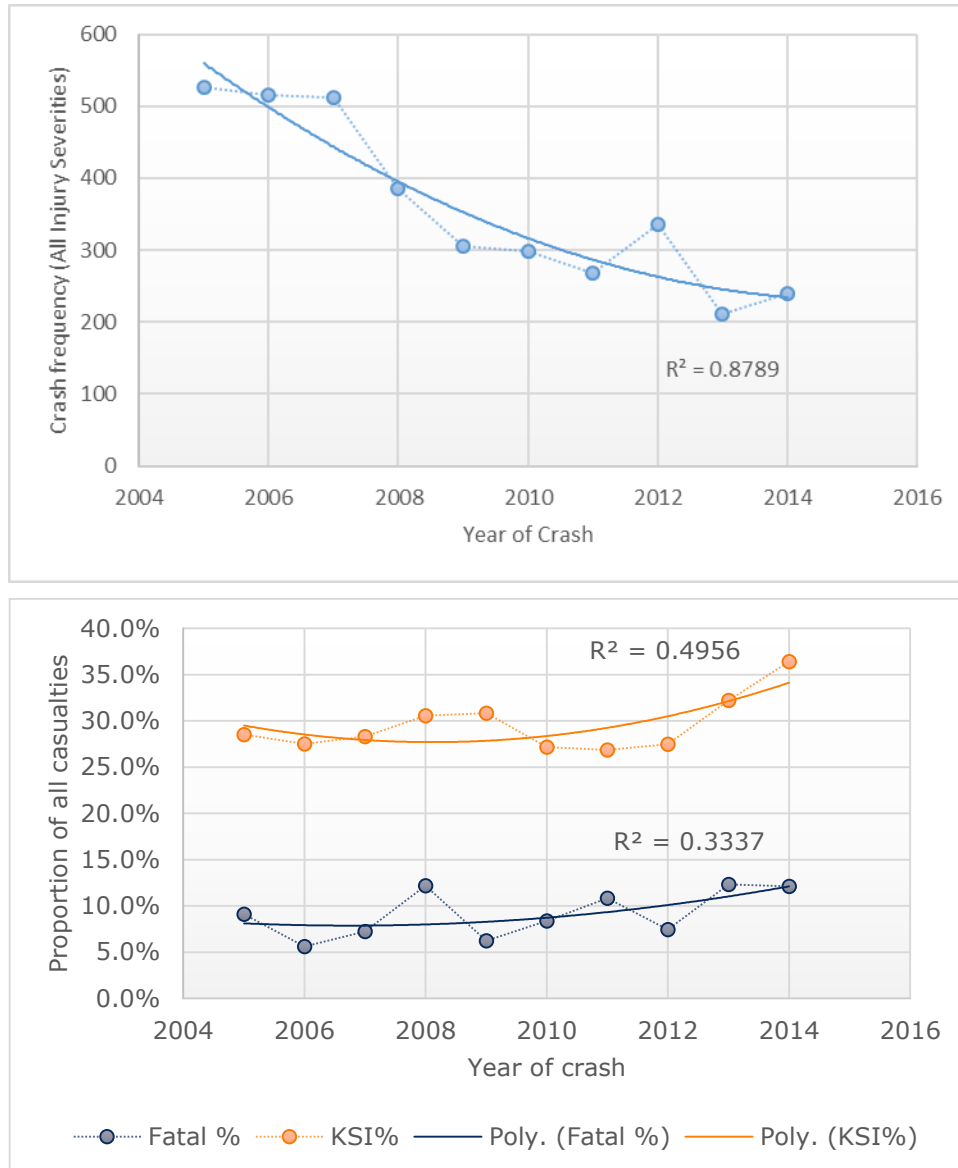

Figure 3: Frequency (top) and injury severity (bottom) for car occupant casualties involved in head-on (front to front) collisions with HGVs>7.5 tonnes. Source: GB Stats 19 accident database

Overall, the head on crashes represent a relatively small proportion (c 10%) of all crashes between cars and HGVs but when they do occur they are much more severe with around 10% resulting in fatalities compared to around 2.5% for all car occupants injured in crashes with HGVs.

The same strong, but slowing, reduction in the frequency of crashes can be observed. However, in this case, there is a suggestion that once a car occupant is involved in a head-on crash with an HGV, the injury severity might be increasing, though the correlation is statistically weak and in the longer term may prove to be random fluctuation. However, if it does prove to be an upward trend, it would be the opposite of expectation based on the increasing market penetration of front underrun protection during this time. Again, this does not necessarily mean that the measure has not had a positive effect, just that if it has had a positive effect, it has been masked by other, larger adverse effects.

Earlier research (Chislett & Robinson, 2010) did not find increases in injury severity but also found no evidence of the expected severity reduction effect of FUP. Their study was also statistically limited such that possible confounding factors could not be easily eliminated. However, analysis of small samples of in-depth data suggested that the effect was not masked by differences in factors such as changes in collision speeds or casualty age.

There is, therefore, at least some limited evidence to suggest that the existing measures may not be working in-service as well as was expected before the legislation.

4 Defining the opportunity for change

One of the fundamental factors limiting the potential of HGVs to absorb energy in a crash with a passenger car has always been the amount of deformation space available between the front of the vehicle and the front axle. Essentially, energy is absorbed by deforming structures and this requires space for structures at the front of the vehicle to crush backwards. The available space is limited by the geometry of the cab, which for many vehicles is a direct function of the commercial need to maximise load space within the overall length constraints imposed by weights and dimensions regulations (Directive 96/53/EC). There are a number of vehicles where load space and length are not a limiting factor, for example for dense heavy loads such as aggregates, or for urban deliveries where quantities are smaller and manoeuvrability more important. However, the economies of scale that come with standardisation of designs have meant that the same basic cab geometry is typically used across all sectors.

The opportunity to change this fundamental limitation has come through Directive (EU) 2015/719, which amends Directive 96/53/EC controlling the weights and dimensions of vehicles circulating in the EU. Amongst other things, this amendment will allow vehicles to exceed the maximum length provided it can be shown that this does not increase load space and that it does improve aerodynamic and safety performance. The aerodynamic benefits are expected to come from permitting a curved profile at the front of the cab, rather than the traditional vertical, flat profile. The Directive foresees the following safety opportunities:

"Enabling vehicles to have a new cab profile would contribute to improving road safety by reducing blind spots in the driver's vision, including those under the windscreen, and ought to help to save the lives of many vulnerable road users such as pedestrians or cyclists. A new cab profile could also incorporate energy absorption structures in the event of a collision. Furthermore, the potential gain in the volume of the cab should improve the driver's safety and comfort. Once improved safety requirements for longer cabs have been developed, consideration can be given to whether it is appropriate to apply them to vehicles which do not benefit from the length extension."

The scope of this report is to consider how, given the new opportunity for a different cab profile, regulatory requirements could be developed in order to ensure that improved energy absorbing structures are implemented that can be shown to improve the level of protection offered to car occupants in collision with the front of the HGV. A secondary consideration will be to ensure wherever possible that whatever procedure is developed can be translated to vehicles that do not benefit from the length extension.

Directive (EU) 2015/719 implements the safety opportunities in article 9a:

"With the aim of improving energy efficiency, in particular as regards the aerodynamic performance of cabs, as well as road safety, vehicles or vehicle combinations which fulfil the requirements laid down in paragraph 2 and which comply with Directive 2007/46/EC may exceed the maximum lengths laid down in point 1.1 of Annex I to this Directive provided that their cabs deliver improved aerodynamic performance, energy efficiency and safety performance. Vehicles or vehicle combinations equipped with such cabs shall comply with point 1.5 of Annex I¹ to this Directive and any exceeding of the maximum lengths shall not result in an increase in the load capacity of those vehicles."

¹ Point 1.5 of Annex 1 defines the manoeuvrability criteria applied to existing vehicles.

Before being placed on the market, the vehicles referred to in paragraph 1 shall be approved in accordance with the rules on type-approval within the framework of Directive 2007/46/EC. By 27 May 2017, the Commission shall assess the need to develop the technical requirements for type-approval of vehicles equipped with such cabs as laid down within that framework, taking into account the following:

- (a) the improved aerodynamic performance of vehicles or vehicle combinations;*
- (b) vulnerable road users, and improvement of their visibility to drivers, in particular by reducing drivers' blind spots;*
- (c) the reduction in damage or injury caused to other road users in the event of a collision;*
- (d) the safety and comfort of drivers.*

To that end, the Commission shall submit, as appropriate, a legislative proposal to amend the relevant rules on type-approval within the framework of Directive 2007/46/EC."

Thus, at this moment in time, the legislation does not specify a maximum length provided load capacity is not increased, the manoeuvrability of the vehicle meets existing minimum standards and efficiency and safety are improved. The technical requirements that may, or may not be required to demonstrate improved performance are to be determined in the Type Approval legislation. In theory, the opportunity to improve the protection offered is, therefore, not currently limited at all by the legislation. However, in practice it will be limited by the requirement to meet existing manoeuvrability criteria and more generally by the principles and wider objectives of the type approval systems which are to maintain the highest levels of safety and environmental performance while minimising the burden of regulation and improving the competitiveness of the EU Automotive industry. This means that improvements will need to demonstrate that the benefits outweigh the costs and that there will be a strong preference for implementing any technical requirements in the UNECE framework of Regulations to encourage global harmonisation.

5 Parameters for evaluation and control

This section explores the relevant accident scenarios a test procedure should be aiming to simulate, the performance characteristics that it should be promoting and the level at which minimum standards might be set, as well as identifying variables that should not influence the result of the test and thus, should be fixed or otherwise excluded.

5.1 Representation of real world collisions

Data from real world accident studies can be used to show the distribution of closing speeds in head on collisions between cars and trucks (Figure 4 and Figure 5).

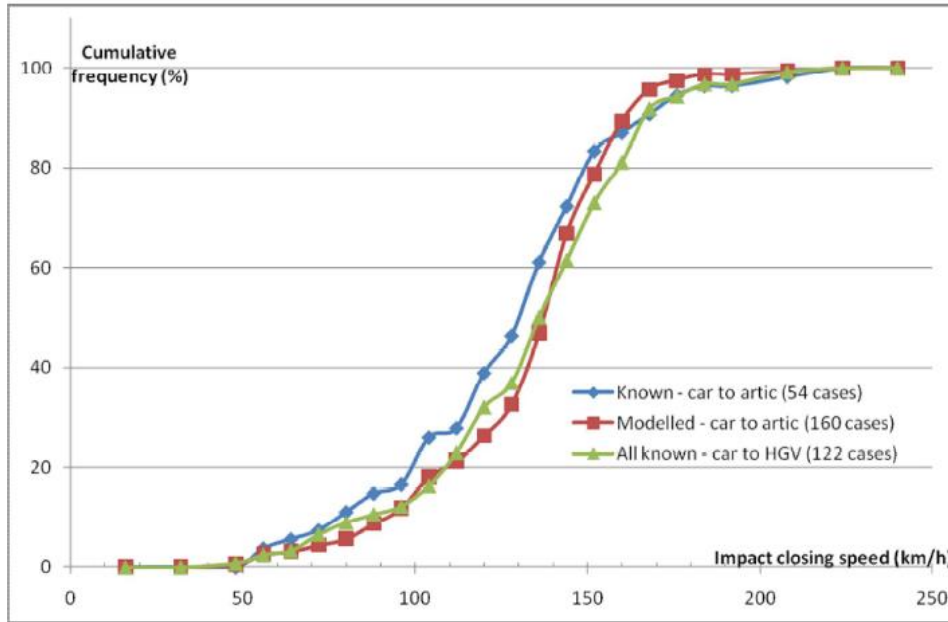

Figure 4: Cumulative frequency of closing speed in GB fatal head on car to truck collisions, source (Robinson, Knight, Robinson, Barlow, & McCrae, 2010)

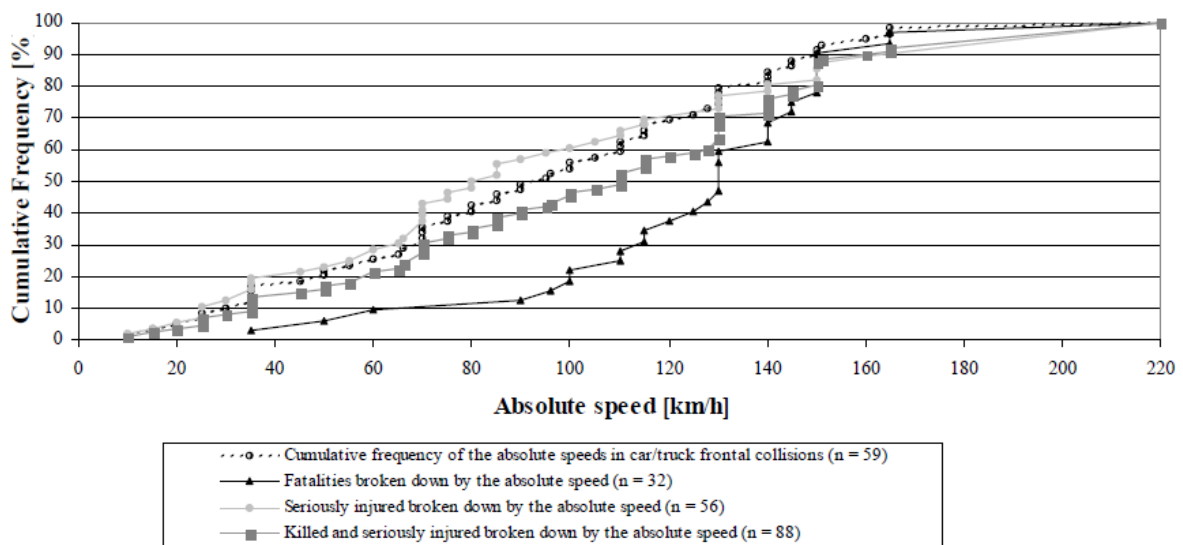

Figure 5: Cumulative frequency of killed or seriously injured casualties in German head on car to truck collisions. Source: (Gwehenberger, Bende, Knight, & Klotwijk, 2004)

When fatalities are considered, the data from GB and Germany are very consistent. This is clearly a high speed crash type with very few, if any occurring at closing speeds of 50 km/h or less and half occurring at closing speeds of more than around 130 – 140 km/h. The mass ratio is such that the velocity of the car will change by close to the total closing speed such that the median change in velocity for a car will be around 130 km/h, roughly double that experienced in a Euro NCAP test (c.64 km/h).

Tests of underrun protection have been undertaken at different speeds. The VC-Compat programme undertook full scale crash tests at between 56 km/h and 75 km/h with a standard length truck and found some benefits of energy absorption. (Forsman, 2002) described the development of Volvo's original EA FUP, which was used as the basis for the VC-COMPAT research tests. They evaluated it at a speed of 65 km/h. (Nilsson & Forsberg) considered the potential of increased length to improve underrun protection and proposed that a speed of 90 km/h would be feasible. Based on this research evidence four performance levels can be considered in respect of speed and they are presented below with an approximation of the proportion of real world crashes that occur at or below that speed:

- R94 equivalent: 56 km/h, 0-5% of head-on fatalities, c.25% of serious injuries
- EuroNCAP equivalent – 64 km/h, 5-10% of fatalities, c.30% of serious injuries
- VC-COMPAT: 75 km/h, 10% of fatalities, c. 45% of serious injuries
- (Nilsson & Forsberg): 90 km/h, 10%-15% fatalities c. 60% of serious injuries

Thus, how well the test procedure represents real world crashes depends quite strongly on the impact speed that it is intended to simulate. The lowest speed category will have only very small effects on fatalities. Given the statistical values used in Regulatory Impact Assessments to quantify the economic benefits of casualty preventions, which typically value fatalities an order of magnitude more highly than serious injuries, then this would be less likely to achieve a positive cost benefit ratio.

The ability of a FUP to provide benefits at these speeds is directly limited by the space available to absorb energy, which is discussed in a subsequent section.

The extent to which car and truck structures overlap in real world collisions also varies from narrow side swipe collisions involving only the outer edges of each vehicle to full overlap involving all of the car structures and most of the truck ones. The frequency of different overlaps observed in studies of head on collisions between cars and trucks are shown in Table 1, below.

Table 1: Distribution of crash overlaps in car to truck head on crashes. Source based on data presented by (Gwehenberger, Bende, Knight, & Klootwijk, 2004)

Overlap (car)	Proportion of all crashes		
	GB Fatal	DE KSI	Mean
0%-25%	6%	40%	23%
25% - 50%	33%	22%	27%
50%-75%	31%	14%	22%
75%-100%	30%	25%	28%

It can be seen that there is a difference between the frequency of fatal collisions in GB and a sample of fatal and serious injury collisions in Germany (DE KSI), mainly in relation to the frequency of very low overlap cases. If a straight average is taken

between the two, it can be seen that the selection of any individual overlap value would be equally valid. Different levels of overlap do place different demands on the FUP device. The greater the overlap, the higher the total force applied to the FUP will be because more of the car structure will be engaged and deforming. However, FUP devices tend to be designed with two vertical supports fixed either side of the chassis rails with a cross-member covering the full width. Controlled energy absorption is often supplied by allowing each support to move backwards and crush energy absorbers. When a full overlap collision takes place the load is spread across both supports and crash cans. Lower overlaps engage only one. In very low overlaps, the longitudinal of the car meets the FUP cross-member outboard of the vertical support, which can overload it and cause the cross-member to fail rather than to transfer the force to the energy absorbers. Thus, arguably, the assessment of an EA FUP can only be considered fully representative if it simulates all three of these loading conditions.

Impact angle also varies in real world collisions, as shown in Table 2, below.

Table 2: Impact angle in head on collisions between cars and trucks. Source: (Gwehenberger, Bende, Knight, & Klootwijk, 2004)

Impact Angle (degrees)	Proportion of all crashes		
	GB Fatal	DE KSI	Mean
0 - 15	49%	66%	58%
15 - 30	46%	18%	39%
30 - 45		14%	
45+	5%	2%	4%

It can be seen that most crashes occur with only small angles and can be considered truly 'head on'. However, a substantial minority occur with impact angles of between 15 and 45 degrees. If a test procedure involves purely longitudinal forces, then it can encourage structures that are strong in one direction but weak in another direction. Such structures can then perform poorly in angled collisions.

5.2 Probability of car occupant injury

The ultimate aim of FUP devices is to limit the probability of injury for the occupants of the car. In car crash testing, anthropometric test devices (ATDs, often referred to as crash test dummies) are used to measure the forces or accelerations applied to the body. Well-proven injury risk functions have been developed to correlate these measured forces with a probability of injury for a real human. Legislative and consumer tests specify limit values for each criterion which are used to either pass or fail the vehicle or to rank its performance.

However, the probability of injury will vary considerably based on characteristics of the car the passenger is in, including both its structure and its restraint system. Thus, if ATDs were to be used to measure the effect of front underrun protection on trucks, the car structure and restraint system characteristics would need to be controlled so as not to influence the results.

A range of research (e.g. (Krusper, 2014)) has shown that both the acceleration of, and intrusion of structure into, the occupant compartment of the car are strongly correlated with the probability of injury. In fact, several research studies (Forsman, 2002) (Krusper, 2014) have used intrusion as a proxy for the probability of car occupant injury in numerical simulations of front underrun protection performance, in order to reduce

the complexity associated with modelling the restraint system. However, for assessment techniques that do not use a full vehicle structure (either physical or virtual) then intrusion cannot be calculated. Acceleration, on the other hand, can be measured in any dynamic test so is more widely applicable. It has often been used to define the input to a sub-system test, for example the EuroNCAP whiplash test where an acceleration pulse is defined by a corridor that is considered representative of a 'typical' crash. However, it has less frequently been used as an output rating metric.

One exception is where the acceleration of a car is used to rate the performance of a roadside restraint system (e.g. Armco central reservation crash barrier). Standards for that type of test have defined an Acceleration Severity Index (ASI). This is essentially the peak acceleration as a proportion of defined limit values in each of three directions, combined into a resultant acceleration. The individual acceleration limit values are 12g longitudinal, 9g lateral and 10g vertical. Overall, an ASI limit of 1.0 is recommended with 1.4 the maximum acceptable limit (Gabauer & Gabler, Undated). Its potential for use as a rating of underrun protection was evaluated by (Schram, Leneman, Zweep, Wismans, & Witteman, 2006) by comparing its relationship to predictions of injury severity on the HARM scale in a wide range of different simulated crashes. The results are shown in Figure 6, below, where the dark dots represent the results of full scale tests undertaken in the VC=COMPAT project.

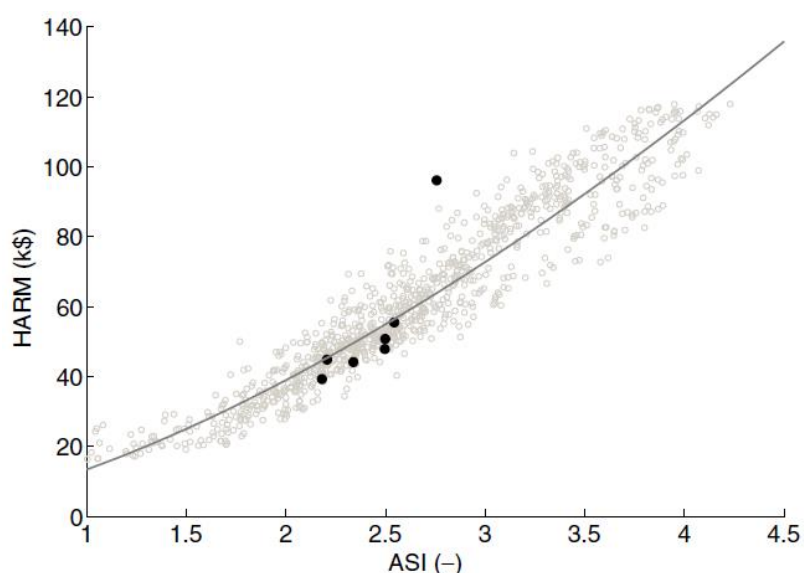

Figure 6: Correlation between Acceleration Severity Index (ASI) and injury severity on the HARM scale. Source: (Schram, Leneman, Zweep, Wismans, & Witteman, 2006)

All but one of the physical tests recorded dummy injury criteria that would have been acceptable in legislation and have scored relatively well in Euro NCAP tests². Thus, based on this a limit value of 2.5 would approximate to equivalence with existing passenger car standard. (Gabauer & Gabler, Undated) gave some limited support to the notion that ASI correlated with injury severity based on real world accidents where longitudinal acceleration was recorded by an Event Data Recorder (EDR). However, a relatively small sample size and a lack of data on serious injuries (MAIS 3+) limited the applicability. No

² The exception involved an impact where the dummies head missed the airbag resulting in an abnormally high head reading

data was presented in respect of the change in velocity so this could not be used to add to the assessment of appropriate limit values. (Sturt & Fell, 2009) also showed a correlation between ASI and specific injury criteria such as HIC. Their tests would have implied a lower limit value of between 2 and 2.1 for equivalence with Euro NCAP. However, the tests they simulated were angled collisions (65 to 80 degrees from straight frontal from the perspective of the car) against concrete roadside barriers. Thus the increased lateral components may have been of influence in the relationship.

The selection of appropriate limit values for either ASI or a straightforward measure of acceleration will vary according to the type of test undertaken, in particular the extent of overlap. The simulations undertaken by (Schram, Leneman, Zweep, Wisman, & Witteman, 2006) were in a range of different conditions for a small selection of vehicles. Figure 7, below, shows longitudinal acceleration values for a wide range of vehicles in one condition, showing B-pillar longitudinal accelerations in NCAP offset deformable barrier tests typically range between 20 and 60g.

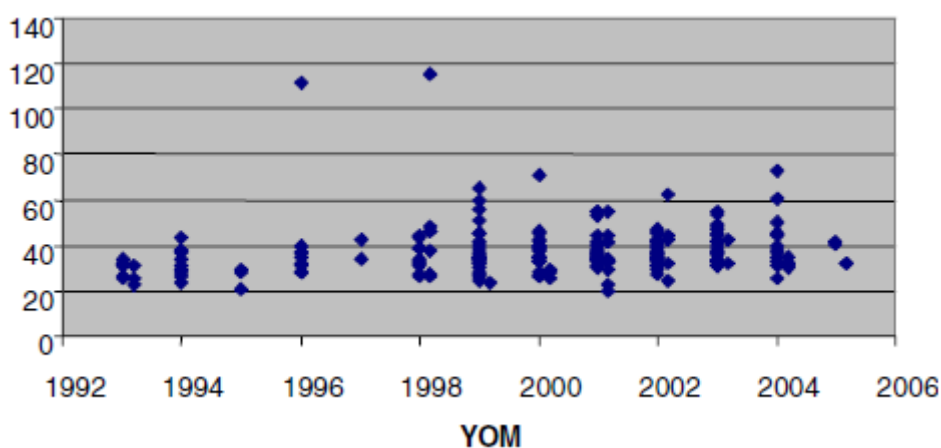

Figure 7: Longitudinal peak accelerations recorded during a 40% offset deformable barrier test in Australian NCAP. Source (Draheim, Hurnall, Case, & Del Beato, 2005)

Full width barrier tests will involve deformation of both car longitudinals and would therefore be expected to provide a stiffer impact with higher deceleration. Thus, the appropriate limit value may need to be fine tuned for the specific test condition. It is clear from the scatter in both Figure 6 and Figure 7 that any single limit value selected will be approximating a range of real world performance and will likely be less accurate a measure of injury probability than the use of dummy measurements in a real vehicle.

5.3 Structural interaction

Even where the probability of injury can be directly measured, it can be beneficial to include additional requirements in relation to features that are known to affect injury risk in the real world. This is particularly relevant where the test does not directly measure the probability of injury and also where a small number of test conditions has to represent a wide range of real world crash configurations.

Structural Interaction is not a direct measure of the probability of injury but has been identified by a number of authors, see for example (Krusper, 2014), as an essential prerequisite of crash compatibility. There are several different aspects to the structural interaction considered separately below.

5.3.1 Vertical alignment

Regulation 93 (UNECE, 1994), controls the alignment of vertical structures with two design restrictive criteria. First, the lower edge of the underrun protection must be positioned vertically no more than 400mm from the ground. Secondly, the cross-member part of the FUP device should be at least 120 mm tall. The intention of these requirements is to ensure that the FUP structure is positioned at a height (400mm to 520 mm from the ground) where the stiff energy absorbing parts of the front of cars will be positioned.

In practice, it has been found that the actual installed height of the FUP varies considerably (Krusper, 2014). In some cases, the ground clearance was as low as 200mm and in many cases the top edge of the cross-member was less than 450mm from the ground. This means that the FUP structures are often lower than the structural members of cars such that it risks the latter passing over the top of the former in a crash. Even where a partial interaction exists, the structures may not deform in a stable crush mechanism as designed. In either case, the self-protection performance of the car would be reduced.

The reason for this situation is that trucks are sold in many different variants, many of which will have slightly different ground clearances. For economies of scale, FUP devices tend to be a standard component. Thus they are designed to achieve the Regulatory geometries in the worst case variant (highest from the ground). In all other variants, the ground clearance is much lower. Improving the control of this alignment would be expected to improve performance in the real world.

Research into the compatibility of passenger cars of different sizes and designs has resulted in proposals to define where passenger car structures should be positioned, as shown in Figure 8, below.

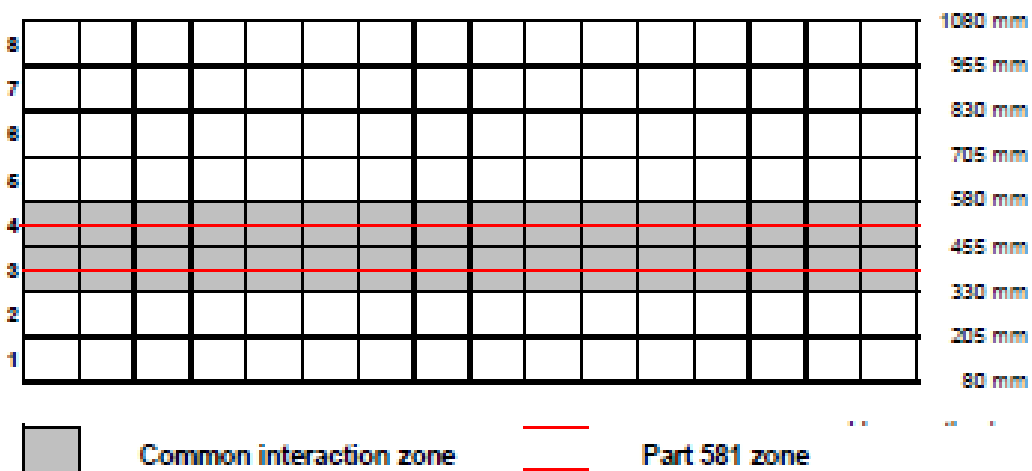

Figure 8: Common interaction zone proposed to harmonise the height of main structural members for passenger cars. Source: (Edwards, Cuerden, & Davies, Current status of the full width deformable barrier test, 2007)

The part 581 zone is a US standard for defining where a secondary energy absorbing structure (SEAS) should be positioned for large SUVs and light trucks in order to ensure interaction with passenger cars. In Europe, the FIMCAR study, part funded by the European Commission, proposed a common interaction zone extending from 330mm from the ground to 580mm from the ground. This extended the Part 581 requirement based on the ability to measure forces in this area on a load cell wall used in an impact

test. (Thompson, Krusper, O'Brien, & Adolph, 2012) expected passenger car geometry to converge such that more cars had their structure in this zone, such that alignment with it would achieve better results in future than it would immediately. However, the expectation was based on the introduction of a full width impact test with assessment criteria based on load cell wall tests. Full width rigid barrier tests have been introduced in Euro NCAP³ and is proposed as a UNECE Regulation. However, in both cases the use of a load cell wall to define compatibility criteria has not been adopted. Thus, convergence on the geometries may remain at least partly voluntary and driven by the US commitment.

5.3.2 Horizontal alignment

5.3.2.1 Car fork effect

A large proportion of the forces exerted by a car when it collides with a flat rigid barrier are applied through two main load paths defined by longitudinal structural members and, later in the impact, through the engine. This is illustrated by Figure 9, below.

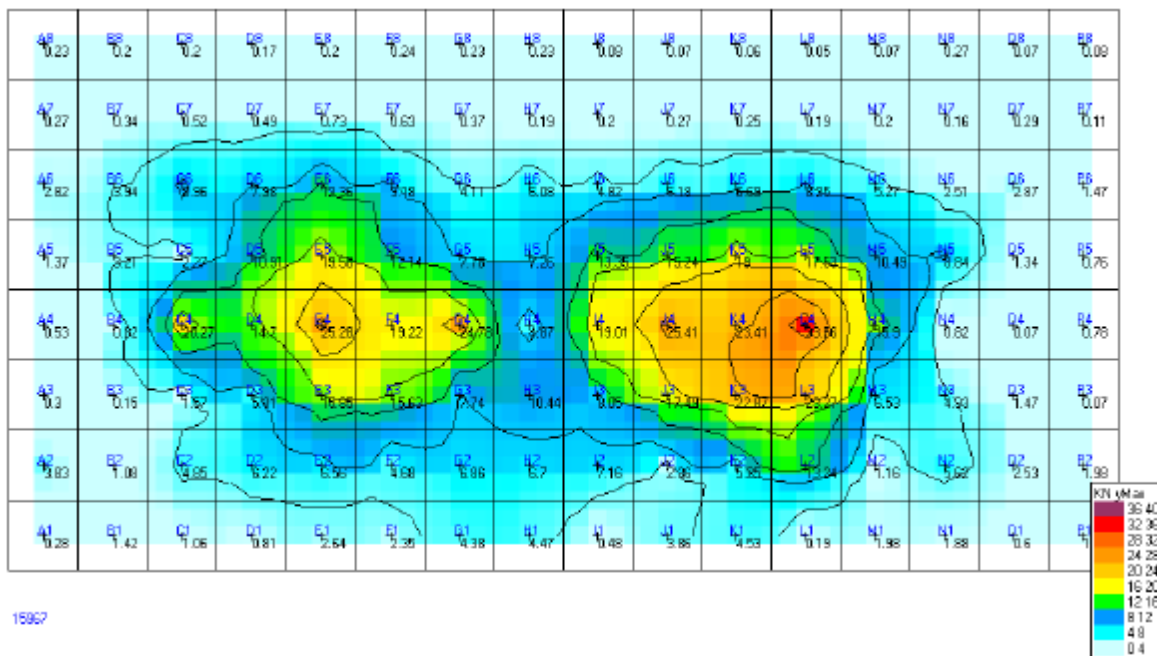

Figure 9: Distribution of the load applied by a car in a collision with a full width barrier. Source: (Edwards M. , Development of a high deceleration full width frontal impact test for Europe, 2009)

The forces were measured on a grid measuring 125 mm by 125 mm. Thus, it can be seen that the highest loads (red and yellow areas) are applied vertically across approximately two rows (250mm) and horizontally in two separate locations. This horizontal separation creates a 'fork effect' when applied to the cross member of a typical FUP. In most FUP devices the loads are transferred to the very stiff chassis by two upright supports either side of the chassis. Depending on the lateral overlap of the collision, it is possible that the two areas of peak force will be positioned either side of one of those supports creating a large moment acting to bend the cross-member around

³ <http://euroncap.blob.core.windows.net/media/20872/full-width-frontal-impact-test-protocol-v102.pdf>

the upright. The FUP Regulation (UNECE, 1994) allows the FUP to be less stiff in these areas.

(Krusper, 2014) showed in numerical simulation that spreading the load horizontally by increasing the bending stiffness of the cross-member improved the structural interaction in crashes and reduced the likelihood of intrusion into the passenger compartment. It is, therefore, desirable to consider a test procedure that increases the stiffness of the cross-member.

5.3.2.2 FUP curve effect

The opportunity to design the front of vehicles for improved aerodynamics, with length constrained only by manoeuvrability criteria, will result in curved profiles at the front of the vehicle when viewed from above (plan view). This is necessary to allow increased length while still being able to turn within the maximum permitted enveloped. The constraints are illustrated in Figure 10, below.

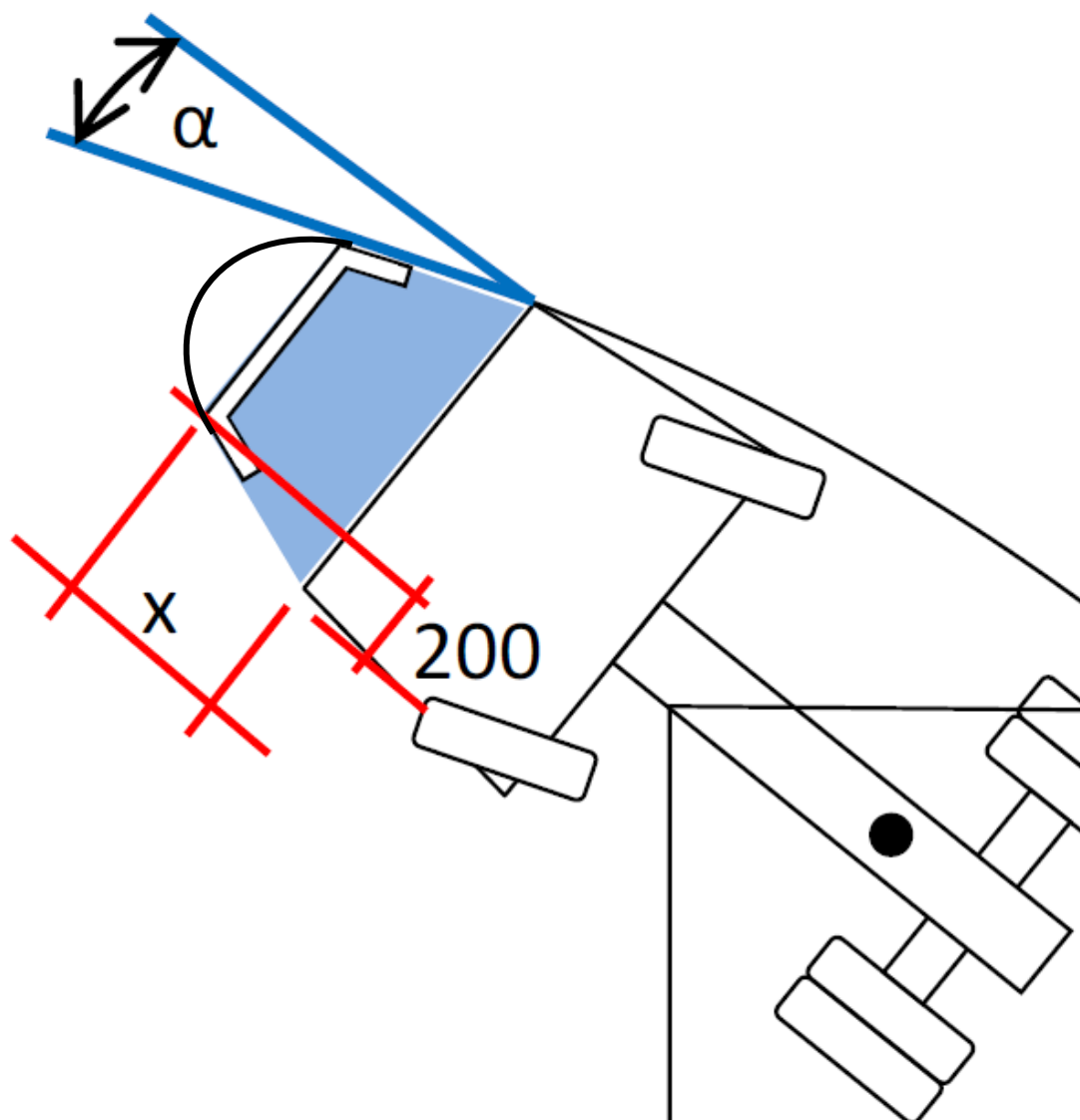

**Figure 10: Factors constraining the shape of FUPs with an extension in length.
Source: Adapted from ACEA presentation to DG MOVE expert group.**

The extent of the required curvature will depend on the length of the extension from the existing vehicle front. At the extreme possible, around 2m, the front of the vehicle would become a sharp point. At more realistic lengths of around 800mm, the effect would be much smaller. Given this profile at the front of the vehicle, the manufacturer will have a choice in terms of implementing the FUP. Firstly, they could implement a flat FUP some distance back from the very front of the vehicle, as illustrated in Figure 10. The structural interaction performance of such a device would depend very strongly on the interaction with the other structures ahead of the vehicle (see section 5.3.4 for more details). Alternatively, they could design a FUP that followed the curved profile at the front.

If the profile of the FUP is curved such that the furthest forward point is the centre of the vehicle, then another 'fork effect' can occur in a full overlap collision as illustrated by the schematic in Figure 11, below.

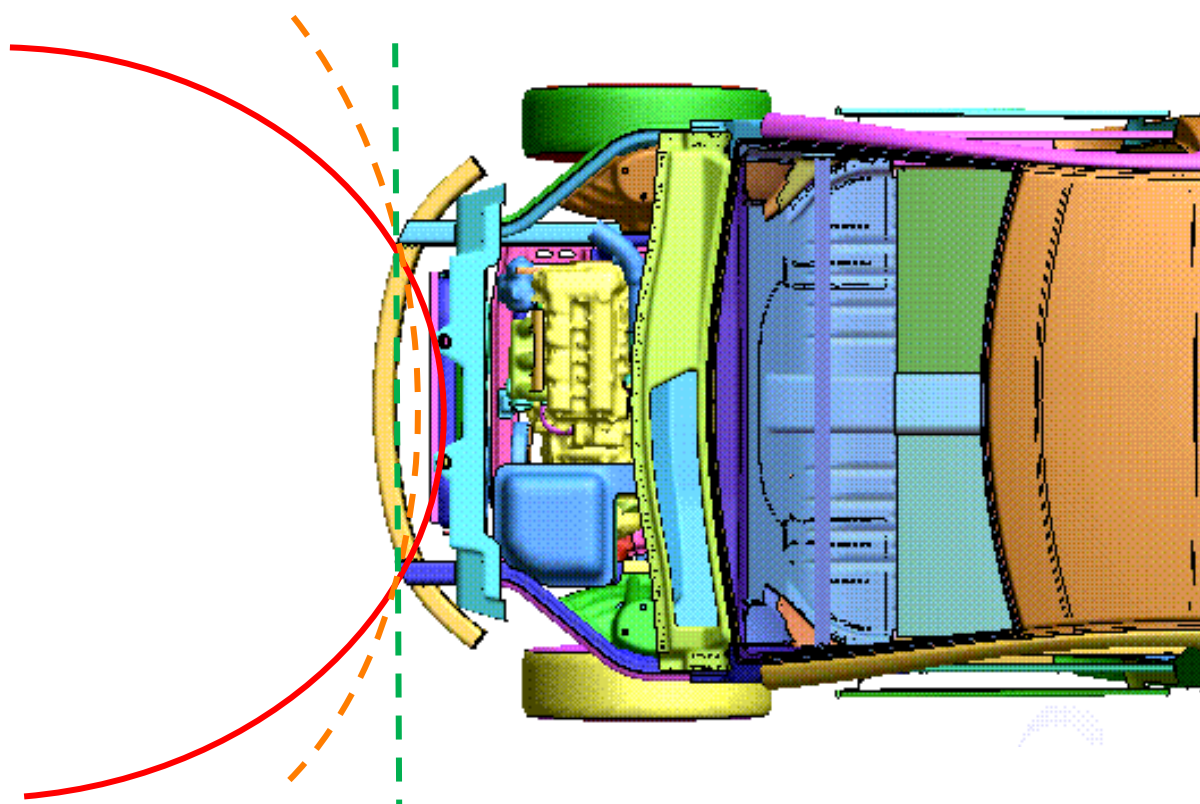

Figure 11: Schematic illustrating possible interaction of curved FUP with car structure at moment contact is made with car longitudinals.

If the centres of the vehicles are aligned laterally, then the first point of stiff contact between vehicles will occur at the centre of the car, at the mid-point between its stiff longitudinals. Depending on the extent of the curvature (red indicating a very curved profile, amber a moderate curve and green flat), this gives rise to the possibility that the 'point' of the FUP could contact the engine of the car before the longitudinals have engaged with the cross-member of the FUP. This has the potential to reduce the effectiveness of the cars self-protection systems. It would, therefore, be desirable for the test procedure to result in a reduced score if such a system occurred, representative of the real world risk of increased injury severity. In the absence of a performance metric this could be limited geometrically by limiting curvature over a central zone of the vehicle but this could also limit maximum length extension and energy absorption potential.

A further effect of a curved profile can be foreseen if a crash with a lateral offset between the centrelines of each vehicle is considered. In this configuration, one of the stiff longitudinals of the car is not engaged at all in the impact, and the second one collides with the FUP at a point somewhere between the centre and the outer edge of the truck.

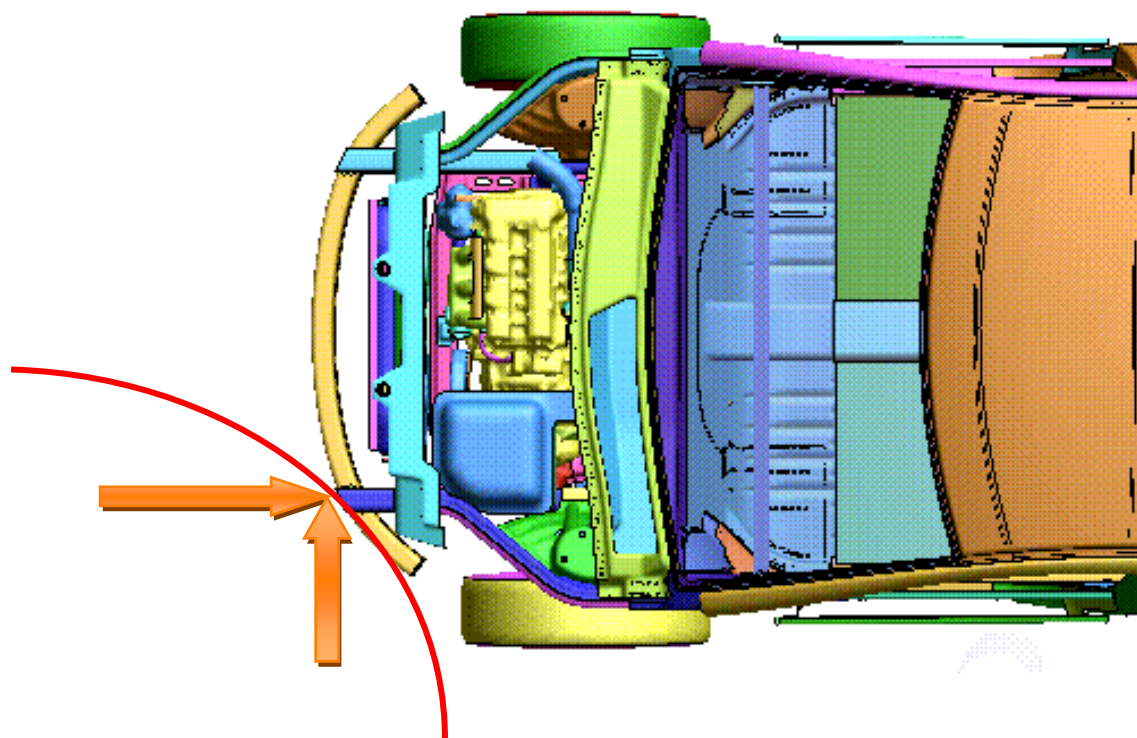

Figure 12: Schematic illustrating potential deflection effect of a curved FUP in an offset collision.

In this situation the car longitudinal is no longer perpendicular to the FUP, so in terms of the localised geometry, it has become an angled collision. Cars are mainly designed for longitudinal collisions and there is, therefore, a risk that the cars energy absorbing structures will deform in a bending mode rather than a crushing mode and may absorb less crash energy as a result, thus increasing the risk of intrusion.

In the US, the National Highway & Traffic Safety Administration (NHTSA) (Saunders, Craig, & Parent, 2012) identified that poor structural interaction was a factor in most remaining fatalities in late-model cars and the oblique collisions formed a significant part of these. They report the development of a moving deformable barrier impact test to evaluate the performance of vehicles in oblique impacts. If implemented as a mandatory minimum standard, this would be expected to improve the performance of passenger cars in oblique tests, thus minimising the increased risk of a curved FUP in an offset collision in future.

It is also possible that the lateral forces applied in the angled collision will tend to deflect the car to one side. If the structures do not positively engage such that the car slides down the side of the FUP then this could also substantially reduce the change in velocity experienced by the car. However, the deflection would have to occur quickly before the longitudinal change in velocity was complete, which would require a low effective friction between the two (substantial angle, minimum deformation). This possibility was studied theoretically by (Lambert & Rechnitzer, 2002). They found that for the deflection effect to occur sufficiently required large angles (i.e. implying a highly curved front with a long

length extension), increasing with overlap. With a 40% overlap, they calculated an angle of around 60 degrees (back from a flat front) would be required to successfully deflect a car.

They also referred to the increased intrusion that may occur in such a situation and overall considered that absorbing energy in the crash would be a better way to reduce the consequences than deflection.

The evidence is, therefore, somewhat limited in this respect, but overall it may be beneficial to limit the proportion of the FUP that is curved or angled backwards. It will not, however, be possible to require a completely flat FUP across the full width.

5.3.3 Stiffness and deformation forces

The protection offered by passenger cars to their occupants is substantial. This has been driven by legislative and consumer tests that involve impact tests with a homogenous barrier, rigid in US, covered with a deformable barrier of relatively uniform stiffness in EU. The protection systems of the car are, therefore, optimised for these conditions. One goal of partner protection for the truck is, therefore, to try to make a collision between a car and a truck as much like the barrier test as possible.

From that point of view, the truck should not deform substantially, or at least very uniformly, in the first phase of the impact where the car is absorbing energy in a controlled manner and the supplementary restraint systems are firing. When the energy absorbing structure at the front of the car has been fully deformed then, if the vehicle has still not been stopped, the passenger cell will begin to deform. Passenger cell stiffness is designed to be greater than that of the frontal structures so at this stage the force and acceleration increase. An important goal of partner protection from the truck point of view will be to begin to absorb crash energy before the passenger cell starts to deform.

The logic above tends to dictate a design of FUP that acts essentially rigidly until a trigger force level is reached at which point it begins to deform and absorb energy. Ideally it would then become essentially rigid again once further deformation risked taller parts of the truck structure contacting the passenger compartment of the car directly (see section 5.5 for more discussion of that objective).

Determining the appropriate trigger force levels and subsequent forces in the energy absorption phase can be complex because different makes, models, and sizes of car have different stiffness characteristics and the force applied to the FUP by any given car will vary depending on the degree of offset or overlap of the collision. (Huibers & de Beer, 2001) studied the frontal force and deformation characteristics of cars involved in five phases of Euro NCAP testing, partially through measurements made by a load cell wall and partly estimated from acceleration profiles. The results are summarised in Figure 13, below.

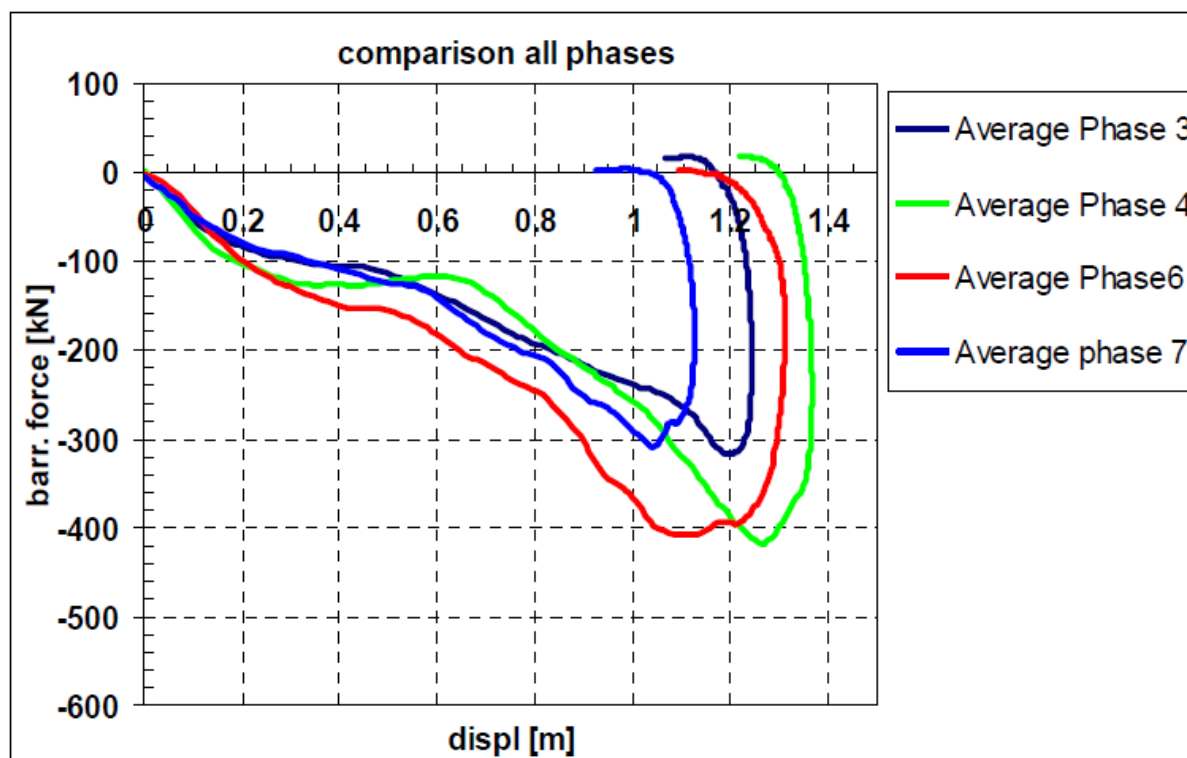

Figure 13: Average force displacement characteristics for different classes⁴ of car. Source (Huibers & de Beer, 2001)

It can be seen that forces rise quickly in the first 20 cm of deformation as softer bumper structures at the leading edge of the vehicle and the barrier itself begins to deform. Between 20 and 60 cm of deformation the force levels mostly increased more slowly between 100 and 150 kN (except for the MPVs/Phase 6 which were stiffer). This phase will be influenced by the deformation of the barrier as well as the vehicle. After 0.6m the force increases further to peaks of around 300 kN for smaller vehicles (phase 3 and 7) and 400kN for larger vehicles (phase 4 and 6). The paper did not link the results to intrusion or injury criteria so it is not known if the peak forces specifically represent the passenger compartment strength but given the extent of deformation (c.1 to 1.4m) this is quite likely.

Based on this data an appropriate trigger force would be between around 150kN and 200 kN, thus ensuring that a stable platform was provided for the initial deformation of the car and the triggering of restraints. The maximum force during the FUP energy absorption phase would be around 300 kN to ensure that for modern cars at least, the passenger compartment did not deform until the FUP had reached the limit of its deformation.

It should be noted that allowing FUP energy absorption at force levels of between 150 and 300 kN would allow FUP deformation at a stage when a large car could still absorb considerable energy without passenger car deformation. However, this would still be expected to occur after the restraints have fired. In addition, the difference in stiffness between small and larger cars will be expected to reduce in future, if proposals are

⁴ Phase 3 denotes medium size family cars e.g. Golf or Focus (n=11); phase 4 is large saloon cars e.g. BMW 5 series, Aud1 A6 (n=7); Phase 6 represents people carriers or MPVs e.g. Renault Espace (n=6); Phase 7 was small family cars e.g. VW Polo (n=6).

accepted to include a mobile deformable barrier test of frontal impact performance in future Regulatory and/or consumer testing regimes (Thompson, Krusper, O'Brien, & Adolph, 2012).

It should also be noted that (Framby & Lantz, 2010) evaluated the reliability and robustness of FUP in different simulated crash circumstances. The FUP design was an energy absorbing one with a trigger force set to pass existing R93 requirements (160 kN applied direct to the FUP support). They found that in many real crash situations the trigger force was not passed such that the energy absorbing phase was not engaged. As such, they recommended reducing the trigger force. However, whether the trigger force was exceeded will depend on a wide range of parameters such as the overlap of the crash, the height of the FUP Cross-Member, the interaction of the car with other stiff components in the truck, how effectively the FUP cross member transmits forces to the support (bending stiffness of the FUP cross-member etc.). It is, therefore, considered more appropriate to base the trigger force on a level that would work well for cars and then ensure that the test procedure encourages designs that will see that force transmitted effectively from the car to the FUP energy absorber to ensure that it works correctly – effectively ensuring good structural interaction with the FUP.

5.3.4 Interaction with other components

To-date, FUPS have been designed and regulated as a separate component that attaches to the rest of the truck. The FUP is situated at bumper level at the front of the vehicle where many other components can also be located. In traditional designs, the chassis rails will be situated a small distance above the FUP, brackets to enable the vehicle to be towed can be located in a similar area as can steering boxes, radiators and other cooling system components, lighting and other ancillary equipment.

Some of this other componentry will not be very stiff and will, therefore, have a negligible contribution to the structural interaction with a passenger car. However, several authors (Krusper, 2014) (Schram, Leneman, Zweep, Wismans, & Witteman, 2006) have found that interaction with these other structures can have an overall adverse effect such that the car is loaded along paths not intended to carry the main loads (e.g. truck tow hooks and radiators interacting directly with car engines) such that energy absorption in the car is reduced. This in turn, reduces the load applied to the FUP through the cars longitudinals, such that the energy absorption in the FUP is also reduced. This is illustrated by Figure 14: Displacement of energy absorber in simulated crashes between car and full truck and where other stiff structures are removed from the truck. Figure 14, below, which shows the displacement of the FUP bracket which is designed to crush the energy absorber in the VC-COMPAT energy absorbing FUP design.

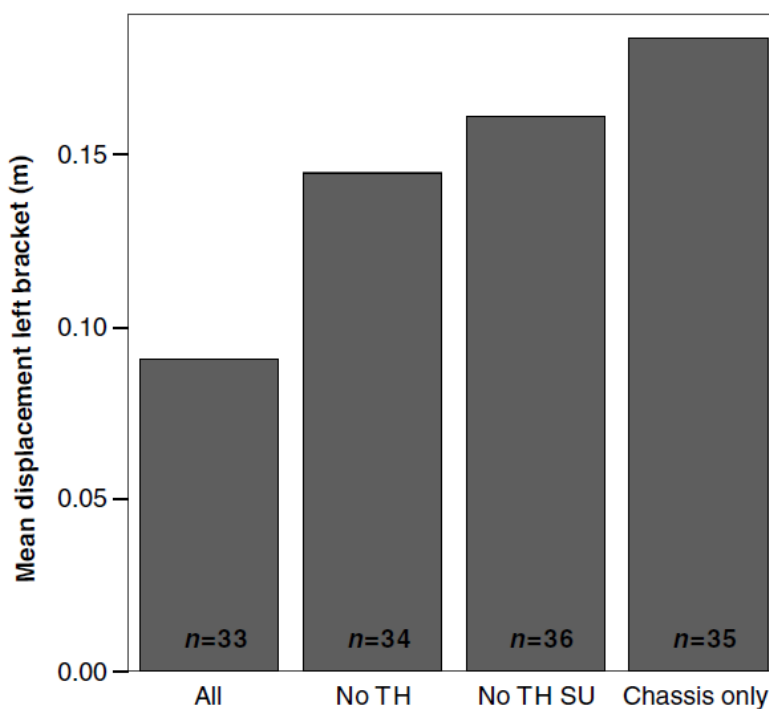

Figure 14: Displacement of energy absorber in simulated crashes between car and full truck and where other stiff structures are removed from the truck⁵. (Schram, Leneman, Zweep, Wismans, & Witteman, 2006)

It can be seen that the Tow Hook makes the single biggest difference but the steering box and radiator both also contributed significantly. Thus, choosing a test that reflects the influence of other structures would be more likely to promote a frontal design that worked well in service.

5.4 Energy absorption

The greater the energy absorbed by the truck in any given crash, the less energy has to be absorbed by the partner car. The less energy that has to be absorbed by the car, the lower the chances are that the passenger cell will suffer structural intrusion, one strong indicator of the probability of injury. This residual chance of intrusion will depend strongly on good structural interaction, as described previously.

(Enomoto & Akiyama, 2005) estimated a 500mm deformation was required to produce sufficient energy absorption to "*cope with a 90 km/h offset crash*" and that this would result in a 50% reduction in fatalities. However, the paper provided few details about the frontal force levels assumed or the quantity of energy absorption expected.

The quantity of energy absorbed by a structure is proportional to both the force applied to it and the distance by which it deforms (energy = Force (F) * Distance(x)). The force applied depends on the stiffness (k) of the material being deformed (F=kx) and the distance by which it is deformed. Thus, a very stiff FUP could absorb a lot of energy by deforming over a very small distance. However, this would require application of a very high force, which would imply a very high deceleration for the passenger car, which would be bad for the occupant. Equally, a lot of energy could be absorbed by a very soft

⁵ All = full truck; No TH = Tow Hook removed; No TH SU = Tow Hook and Steering Unit removed; chassis only = Tow Hook, Steering Unit and Cooling pack removed.

FUP which would minimise the force and deceleration of the car but would require a very long crush distance. Thus, the design of a FUP will be a compromise between minimising car deceleration and minimising the crush depth required.

(Robinson, Knight, Robinson, Barlow, & McCrae, 2010) used the results from VC-Compat and other studies to explore the potential of EA FUPS with a greater crush depth by working out the speeds at which dummy readings would become critical for different cars in tests with rigid and ea fups. "Equivalent energy speeds" were then derived to define closing speeds at which those thresholds would be passed given energy absorbing FUPS with varying levels of crush depth and for cars and trucks with different masses. This resulted in the following graph.

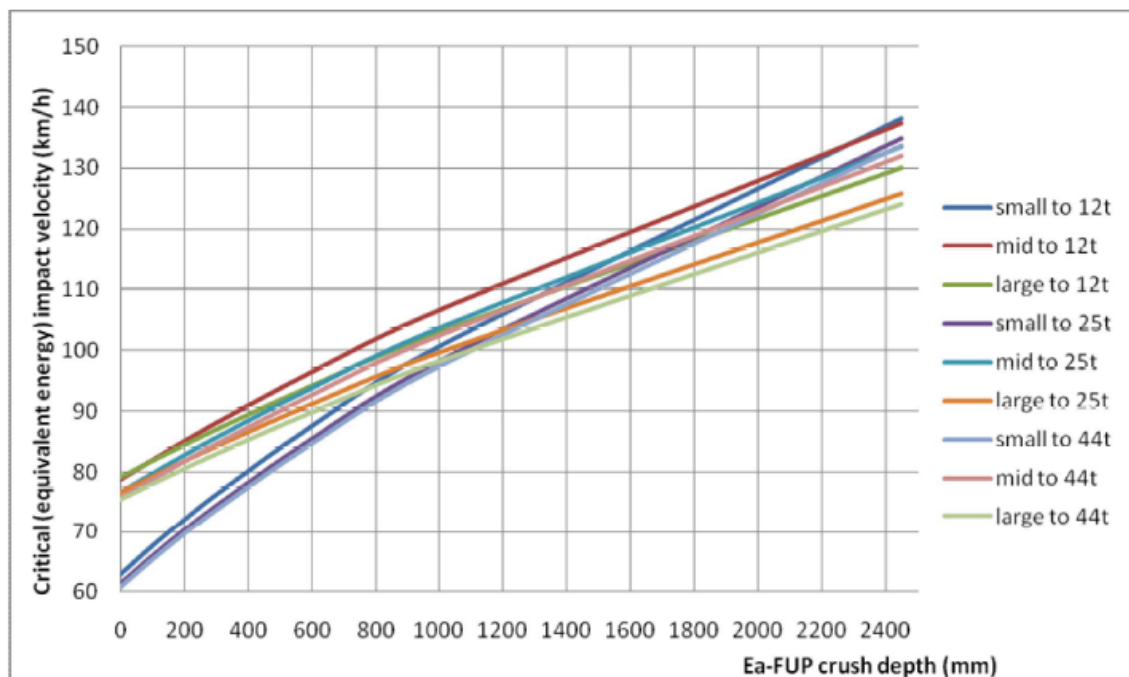

Figure 15: FUP crush depth required for energy equivalence to a 'good' injury outcome with existing FUPS for different vehicle mass combinations. Source: (Robinson, Knight, Robinson, Barlow, & McCrae, 2010)

The analysis suggests that at collision speeds of 64 km/h good protection should always be available to modern passenger cars even with near zero FUP deformation (perfectly rigid FUPS), assuming good interaction with the car structure. At closing speeds of 75 km/h, the deformation depth required would be around 0 to 300mm. At closing speeds of 90 km/h a crush depth of between around 400mm and 800mm on the truck, depending on the masses of the vehicles involved. Based on the force assumptions used by (Robinson, Knight, Robinson, Barlow, & McCrae, 2010) (constant 250kN), this implies an energy absorption capacity of between 100kJ and 200kJ.

Most materials conform to a linear stiffness characteristic in compression, that is, the force required to deform them increases the greater the deformation. However, materials have been designed that do approximate deformation under a constant load. This is achieved because the material does not compress directly but bends and buckles one piece at a time to create folds of material. Thus, to require in practice, energy absorption as assumed by (Robinson, Knight, Robinson, Barlow, & McCrae, 2010) while also meeting the requirement that the FUP should not initially deform until the car has crushed substantially, would require a trigger force of 250 kN.

However, if the FUP design employed an energy absorber that did not crush at constant load then using a trigger force of 250 kN would not guarantee sufficient energy absorption because the load required might increase above 300kN well before 800mm deformation was reached. For such a material, a lower trigger force would be appropriate, allowing a reduced stiffness material to be used and to be fully crushed.

Therefore, to provide a test that works for different approaches to FUP energy absorption, a lower trigger force combined with a minimum requirement for energy absorption is likely to be required.

In most prototype designs of energy absorbing FUP, the energy absorption has been focussed in defined 'crash cans' or energy absorbers located at the FUP mounting points either side of the chassis. These are designed to crush longitudinally. The longer such a 'crash can' becomes the more it becomes exposed to the risk that slightly off-axis loading can result in it failing through bending rather than longitudinal crush. This may in practice be a factor limiting the maximum amount of energy that can be absorbed, depending on the design.

Relatively few designs of Energy absorbing FUP have been produced with the specific intention of fitment on an HGV with extended length at the front. (Matheis & Welfers, 2011) produced a design that moved the FUP forward away from other structures that would interfere in the energy absorption. However, the crush cans were limited to 280mm in length. It is understood that the stability was one factor limiting the length of energy absorber proposed.

(Nilsson & Forsberg) proposed three different designs based on an increased length of 600mm at the front of the vehicle. Each design produced up to 800mm of crush by utilising 200mm underneath the front of the chassis rails (which would be available in existing truck designs).

Two of the three designs (Nilsson & Forsberg) met the success criteria the authors defined, which suggests that this extent of energy absorption is feasible. However, at this stage, the length increase permitted by Directive 2015/719 is voluntary. The requirement is written such that IF length is increased, partner protection must be improved. Specifying a minimum quantity of energy absorption will, therefore, define a minimum length increase in practice if it exceeds the quantity of energy that can be absorbed in the existing space underneath the front of a truck (c. 200mm). Given that different lengths may be chosen by different manufacturers or for different models and that this may be based pre-dominantly on aerodynamic considerations, it may be necessary to define the minimum energy absorption required at different levels based on the additional length requested by the manufacturer.

5.5 Prevention of underrun

Underrun can be defined purely in terms of the vertical interaction defined in section 5.3.1. However, when applied to collisions between cars and trucks it is typically interpreted as the kind of gross underrun that occurs when a FUP is not fitted, or fails, such that the front of the car passes completely underneath the main chassis members of the truck, as illustrated in Figure 16, below.



Figure 16: Example of gross underrun.

Regulation 93 (UNECE, 1994) is worded such that after application of the test forces, the FUP must be positioned no more than 400mm back from the front of the vehicle. It is understood that this limit was based around the need to ensure that the higher structures at the front of the vehicle (including the very stiff chassis rails) did not contact the windscreen area of the car after both the deformation of the FUP and the front of the car.

There will be a similar requirement for any revised requirement that requires energy absorption, particularly if the minimum standard is such that the deformation required exceeds 400mm. For example, if the front of a truck were extended by 800mm under the conditions imposed by the revised weights and dimensions directive, the chassis beams could be extended close to the front of the vehicle providing enough curvature was retained to meet aerodynamic requirements, perhaps to within 200mm of the foremost point of the vehicle. If the FUP requirements were such that it must deform by 800mm then the final position of the FUP would be at least 800mm behind the foremost point of the vehicle and at least 600mm behind the leading edge of the chassis beam. In such a situation, the FUP could absorb energy perfectly but still allow severe intrusion into the passenger compartment from contact with the chassis beams.

This requirement can also create conflict with an aim to absorb energy in a truck to truck collision, which is the type of crash where truck occupants are most commonly killed or seriously injured. Energy absorption for such collisions will necessarily be more stiff than those for car collisions and will be positioned further from the ground to ensure interaction with stiff parts of the partner truck. (Matheis & Welfers, 2011) exploited the idea of increased cab length at the front of an HGV to design a crash management concept aimed at consideration of both problems, as illustrated in Figure 17, below.

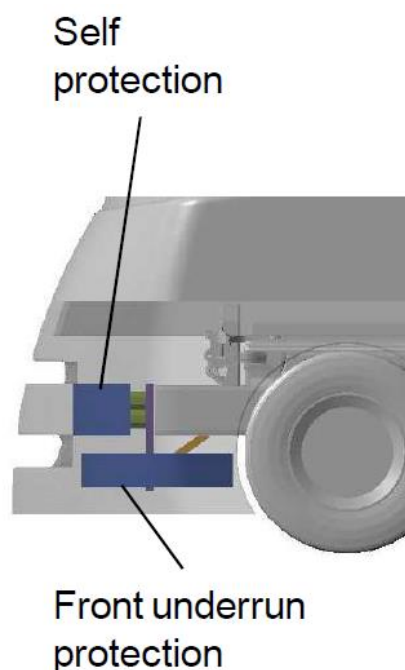

Figure 17: Illustration of a crash management concept considering both self-protection in truck to truck collisions and partner protection in truck to car collisions. Source: (Matheis & Welfers, 2011)

It can be seen that in the layout proposed, the deformation of the front underrun protection would need to be limited to around 400mm in order to avoid gross underrun of the self-protection structure. Increasing energy absorption would require the FUP to protrude forward of the self-protection structure, which would act to limit the potential of the latter.

Thus, an energy absorbing FUP test procedure would need to involve all relevant structures and an impactor with a geometry representing both bumper beam and passenger compartment, or the geometry of the truck would need to be restricted such that gross underrun could not occur.

5.6 Repeatability and reproducibility

In order to ensure fairness for manufacturers, any test procedure must be repeatable. That is, if the test is repeated by the same test authority multiple times, the result will be the same within an acceptably small tolerance. This allows manufacturers to design products to meet the requirements with a high degree of confidence that the design will pass the test.

European Type Approval is a scheme where a single approval by an approved body in any Member State will result in the product being approved for sale in any Member State. Many different approval bodies exist in different Member States. Any test procedure used must, therefore, also be reproducible. That is, the same result will be achieved if the same design is tested in multiple different test facilities, even if different personnel and different equipment is used.

6 Candidate Assessment Techniques

For each candidate go through how well it works for all the different parameters to evaluate or control and curved v straight FUP

6.1 Design Requirements

Design requirements are well suited to parameters where performance is directly related to the geometry, for example:

- Structural interaction: Vertical Alignment – this can be well defined by defining a proportion of the common interaction zone that must be uniformly covered by structure defined as part of the FUP Cross-Member.
- Structural interaction: Horizontal alignment, FUP curvature – this could be controlled by simply limiting the minimum radius of curvature across a defined width of the vehicle.
- Overlap – suitability for low overlaps can be partially defined by specifying the degree to which the FUP must cover the full width of the vehicle.
- Stiffness: interaction with other components – can be governed by placing limits on the positioning of certain key components (chassis beams, engine block, cooling pack, steering box, tow hooks etc) known to influence structural interaction between car and FUP
- Prevention of underrun – as above but including consideration of post deformation positions.

The above criteria would ensure aspects of intended performance are met but do not prescribe single designs, which would limit innovation in the industry. However, there are many other factors where ensuring the required performance was achieved would require severe limitation of the design and innovation. For example, prescribing the strength via a design requirement needs material properties and geometry to be defined at a very detailed level that would severely limit innovation.

6.2 Quasi static tests

Quasi static tests have the advantage that they are relatively low cost and simple to undertake as well as offering good repeatability and reproducibility. The following parameters could be assessed:

- Horizontal alignment: Car fork effect – Loads approximating to the total load applied by the car in the defined overlap and speed configuration designed for can be applied direct to the main elements that transmit the force to the chassis (uprights). In a separate test point loads representing the load applied by a single vehicle longitudinal can be applied to worst case positions on the cross -member (i.e. mid-point between supports and outer extremes of sections connected to only one support) with more restrictive deformation requirements to encourage stiff cross-members that transmit load to the uprights and energy absorbers well. This would be expected to ensure good performance in a range of overlap conditions.
- Stiffness matching – Force deflection corridors could be defined to help ensure that the FUP provides a stable base for the car to interact with before deforming to absorb its own energy. Trigger and maximum forces could be easily defined

and controlled. However, materials behave differently when loaded very quickly compared to when they are loaded slowly. Thus, the actual trigger forces might vary in real life depending on the shock loading and dynamic characteristics of the materials used.

- If force and deflection was monitored during each test than the energy absorbed by the structure could also be assessed (area under the force deflection curve). However, this would also be only an approximation of reality because the energy actually absorbed in a real impact would be different as a result of the speed the load was applied at and the amount of difference (or error) would vary depending on the materials used.
- Underrun – if the FUP was required to be assessed with the full front portion of the chassis positioned as it would be in service, then the risk of underrun could be assessed by including an appropriately positioned additional impactor face on the rig. In this way if the high level impactor interacted with the chassis, the maximum load would quickly be reached with little further energy absorption, ending the test and making it more difficult to meet the energy absorption target.

In general, a curved FUP would be difficult to assess with quasi-static testing. Firstly, the quasi static test would not simulate the horizontal alignment structural interaction effects identified with the 'point' of the curve at the front centre of the vehicle, or with the angled impact and deflection characteristics in an offset collision with just one side of the vehicle. Secondly, when a longitudinal load is applied through a ram in a quasi-static test to a curved FUP, it is not applied perpendicular to the surface (except in the centre, assuming a centred and symmetrical curve). This will create a lateral force to the side that could create problems for the stability of the test rig and may result in loading of the FUP that was not representative of a real collision.

It is possible that these problems could be solved by creative re-design of the test apparatus, for example using a lateral support for the ram, close to the point of application, or by resolving forces according to the angle of the cross-member and applying the components of force perpendicular to, and along, the axis of the cross-member. However, these have not been tried and would make the procedure more complex and potentially less representative.

Thus, quasi-static tests would be best employed for straight FUPS only, either in combination with a design requirement limiting curvature or alongside a different test method for a curved FUP.

6.3 Dynamic impact tests

Dynamic impact tests have the inherent advantage of more closely representing a real collision. Thus, they have the potential for more accurate evaluation of trigger forces and energy absorption in particular, as well as offering the potential to assess any design, straight or curved, and consider effects such as deflection. In addition to this, it becomes possible to directly measure parameters that have been shown to correlate with the probability of injury, such as acceleration or dummy criteria.

However, dynamic tests can be undertaken in many different forms, each of which may have advantages and disadvantages.

6.3.1 Fixed or movable impactor

In real world collisions, both car and truck are usually moving towards each other. In energy terms, this can be simulated by one vehicle moving at a speed equivalent to the real world closing speed. Thus, a crash where a car travelling 50 km/h collides head on with a truck travelling at 40 km/h can be simulated by an impact where one of the vehicles is travelling 90 km/h before impact and collides with the other vehicle while stationary. In theory, either the truck or the car can be moving. However, it would be impractical for the truck to be moving because most crash test facilities would not have the power/space to accelerate a truck to 90 km/h before impact and allow safe run-off after collision.

It is, therefore, more practical to keep the truck (or FUP sub-assembly) as the stationary partner and use a car (or substitute impact trolley) as the only moving partner prior to impact.

The truck can be free to move provided it is ballasted to an appropriate mass such that the delta-V is appropriate. A rigidly fixed FUP installation could be considered but would require small changes to the car test speed to account for the slightly increased car delta-V that it would cause.

6.3.2 Full truck or FUP sub-assembly

This consideration relates mainly to the assessment of structural interaction with components that do not form part of the FUP and the prevention of underrun. The use of a full truck would maximise the realism of the assessment. However, such a test would cause damage to a wide range of structures, plastic trims, body panels, lighting etc. that would be highly unlikely to significantly affect the test result. Using a simple FUP sub-assembly only would mean that the dynamic test would take no account of the structural interaction with non-FUP components. This would either be ignored (risking reduced performance in real world crashes) or would need to be controlled by design requirements (risking restrictions on innovation or other unintended consequences).

A hybrid is possible whereby the test is undertaken with the FUP and a defined set of additional structures. However, it can be difficult to define the structures that should be included based on a realistic assessment of whether they will affect the result, and to mount them in a realistic way during the test such that the effect they have closely resembles the effect that would be observed in a full test.

6.3.3 Rigid impactor

The use of a mobile trolley mounted with a rigid impactor face to represent the car was assessed by (Duque, Damm, Grover, & de Co, 2006). The main advantage of this approach is that it reduces to near zero the energy absorbed by the trolley (car) such that all of the loss of kinetic energy of the trolley can be considered to have been dissipated in the deformation of the FUP. It therefore allows a relatively accurate assessment of the energy absorption capabilities of the FUP. However, to avoid unrealistically overloading the FUP, the initial speed of the trolley must be reduced by an amount comparable to the energy that would be absorbed in a real car, or a deformable barrier face, such that the impact is over once the FUP energy absorption phase is complete. This is difficult to control accurately because it depends partly on the structure and design of the FUP as well as of the car or barrier it is replacing.

With a rigid impact face it is not possible to measure the performance of the FUP in terms of the horizontal structural interaction parameters and it would be more difficult to measure the vertical interaction performance, particularly with non-FUP structures. For example, if the rigid barrier face interacted with a tow hook it would reduce the force on the FUP to zero (unless the tow hook broke free) which would substantially reduce the measured energy absorption. In a real crash this would only partially reduce the force on the FUP. Thus, the effect of the tow hook would be substantially exaggerated.

6.3.4 Mobile Deformable Barrier (AE-MDB)

Placing a deformable barrier on the impact face of the trolley representing the car in a dynamic test, would make the trolley behave more like the front of a car. This is the technique used in side impact tests for Euro NCAP. Recently (2015) the specification of the trolley has changed, to increase its mass from 0.95 tonnes to 1.3 tonnes and to increase the stiffness of the barrier, such that it more closely reflects modern cars. The geometry of the barrier is defined in Figure 18, below.

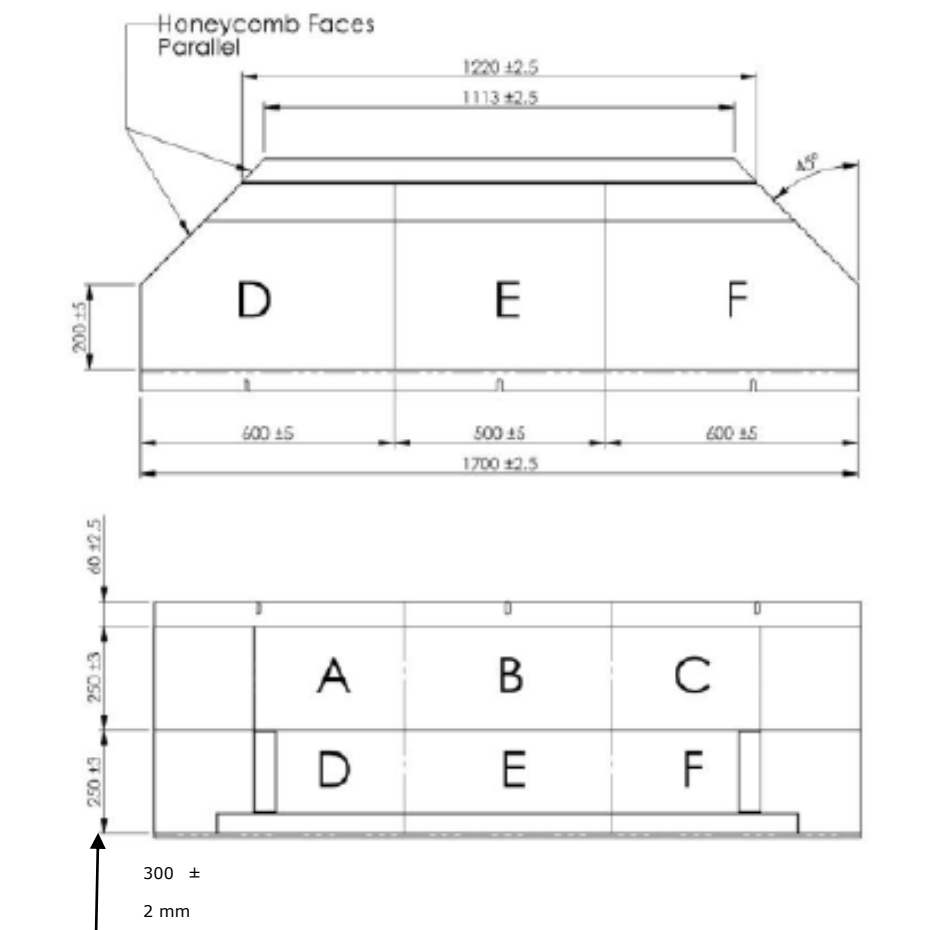

Figure 18: Geometry viewed from underneath (top) and from the front (bottom) of AE-MDB used in Euro NCAP side impact tests. Source: (Euro NCAP, 2013)

The barrier is designed for all of its surface to engage with the side of a car in an impact speed of 50 km/h. The change in velocity experienced by the barrier will be around 25 km/h in collisions with small cars of similar (1.3 tonne) mass but will be much more in collision with larger cars, depending on the exact mass ratios. When colliding with a small car the total kinetic energy lost in the crash will be around 63 kJ and this would be

expected to increase to around 76 kJ in collision with a 2 tonne car. If the car and the barrier were of equal stiffness, then the crush would be equal and each would absorb around half of the energy. Larger cars may also tend to be stiffer such that the share absorbed by the barrier increases.

The specification of the barrier (Euro NCAP, 2013) states that the barrier must absorb approximately 62 kJ of energy at a deformation of approximately 340 mm and this is demonstrated in a test against a rigid wall at 35 km/h. Thus, the energy absorption capability is sufficient in principle to comfortably take its share of the total energy lost during the actual test, even with a heavy car, without 'bottoming out' the barrier.

Compliance is also required with a force deflection corridor for each block of material. Thus, the peak total force exerted by the barrier must be between around 260kN and 300kN. This is well above the trigger forces identified as suitable for energy absorbing FUPs but below the peak forces applied by passenger cars in the higher speed frontal ODB test.

However, both the side impact test and the verification test involve interaction with the whole area of the barrier. In a FUP test the structure would not be crushed uniformly across its entire surface (1.7m wide and 500mm tall). Firstly, if a partial overlap was simulated then not all of the width of the barrier would be used. Secondly, the main points of interaction would be the FUP cross member and the upright supports. If only the cross-member is considered but in a full overlap collision, then the ground clearance might be 300 mm with a cross member height of 120mm. This means that slightly less than half of blocks D, E, and F of the AE-MDB would be crushed.

The honeycomb structure is designed to crush when a certain pressure is applied. Thus, if the area over which force is applied is halved then the pressure would be doubled. This means that the area in contact with the FUP cross member would crush at around half of the force that would be required to crush the whole of that block. The force deflection corridors prescribed for the lower rows are shown in Figure 19, below.

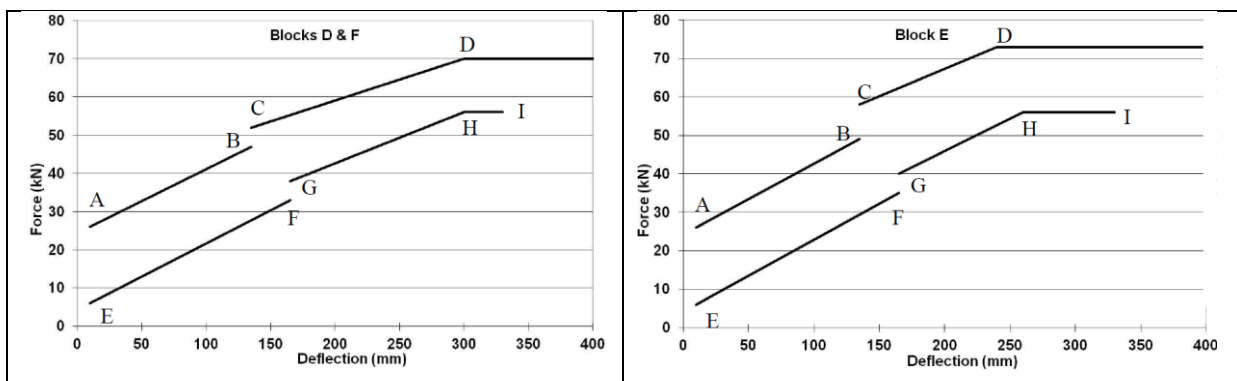

Figure 19: Prescribed force deflection corridors for honeycomb blocks in the lower row. Source (Euro NCAP, 2013)

Thus, when the whole of each block is engaged the total force from the three blocks will be approximately 213 kN (sum of maximum for each of the three blocks). This block covers the zone from 300mm above the ground to 550 mm above the ground and, therefore encompasses the whole common interaction zone defined for passenger car interaction in frontal impacts. As such, ensuring full structural interaction for the FUP with the whole of that zone would mean the max force applied before bottoming out the barrier would be around 200 kN. Halving this to represent only interaction with the

currently legislative minimum FUP cross member would suggest the maximum force applied to the cross-member would only be around 107 kN.

Thus, in the best case, the total force applied by the barrier before bottoming out would be less than is defined as a desirable average force for a FUP to absorb energy at (250kN). In the worst case, the FUP trigger force (150kN – 200kN) would not be exceeded before bottoming out the barrier. This does not mean that the energy absorption of the FUP would not be correctly activated during a test, provided that the initial speed was sufficiently high. However, it does mean that during the FUP deformation phase the impactor representing the car would essentially become rigid where it interacts with the FUP. This may mean that the crash energy is not divided between the vehicles in a way representative of the real world. Initial speeds of the barriers may, therefore, need to be varied to compensate for this as much as possible. Ideally a modified barrier design would be used which would have stiffness's and crushable depths more representative of a car in a 64 km/h collision with an existing, R93 compliant, FUPS structure.

In terms of structural interaction, structures other than the FUP that come into contact with the barrier will reduce the amount of force applied to the FUP, reducing the energy absorption in the FUP and potentially increase the acceleration of the trolley. Depending on the exact test metrics this could be detected and reflected in the score. In terms of vertical alignment, use of this test with a limit defined in terms of acceleration would be likely to avoid extremes of misalignment because a reduced acceleration in the initial phase when the barrier first interacts with the FUP will be likely to result in a higher acceleration peak later when the both the barrier and FUP energy absorption has bottomed out before the impact is over and the interaction becomes more rigid. In contrast, increasing the height of the cross-member would increase trolley acceleration prior to bottoming out the barrier, which would require a reduced FUP deformation length to absorb the remaining energy, or a reduced FUP stiffness, which would improve the score.

Prevention of gross underrun would be partially measured in this test. The height of the barrier is 800mm and this would interact with some but not all truck chassis members. Where it did interact, the chassis members would bottom out the barrier when the top part had crushed by around 350 – 400mm. If the barrier and FUP had not absorbed all the energy and brought the trolley to rest by that point, then the acceleration would rise rapidly at that point. Ideally the height of the barrier would be increased to 1000mm to guarantee interaction with most truck chassis rails. Consideration could also be given to further reductions of the barrier stiffness in the top part of the barrier, or removal of the honeycomb leaving only a rigid back plate. This is because most cars do not have structure at this height until the chassis members meet the A-pillars.

For the horizontal interaction, the potential for deflection would be simulated to some degree, though the fidelity of the interface between vehicles would be imperfect. The problem with a pointed 'nose' of the FUP would also be reflected to some extent because the barrier would bottom out earlier in this area reducing the energy absorbed. The 'fork effect' of the car would also be accounted for to some degree because if the cross member was soft in unsupported areas it would not deform the barrier much in these areas and deformation would be deeper around the uprights, resulting in reduced overall energy absorption of the barrier. However, this effect would be limited because the centre block is of similar stiffness to the outer blocks, whereas the force applied by a real car would be larger around the longitudinals.

6.3.5 *Progressive deformable barrier*

The progressive deformable barrier was initially developed for use as a potential new frontal test intended to improve car to car compatibility. The benefits of its use in a mobile barrier test procedure for car impact tests was discussed in (Adolph, Ott, Eickhoff, & Johannsen, 2015). It was found that the existing offset deformable barrier test used in UNECE R94 and Euro NCAP was equivalent to a collision with a vehicle of the same size. This tended to encourage stiffness mismatches because to achieve good self-protection in the test required heavier cars to be stiffer than light cars. The replacement of the fixed barrier with a moving trolley of fixed, average mass, means that the change in velocity experienced by heavier cars is less than that of light cars. This reflects the most common crash types in the real world and tends to increase the stiffness required for small cars to do well and decrease stiffness required for larger cars, improving that aspect of compatibility.

The above is not strictly relevant to consideration of the use of the PDB as opposed to any other barrier in a test of EA FUP. However, the research notes that the PDB is much deeper and stiffer than other barriers. Its stiffness is progressive and it has upper and lower load levels intended to be more representative of an average car. The design was intended to create shear forces on the vertical and lateral connections of the front structures of the test object and to allow the stiff structures of the test car to be clearly identified without bottoming out of the barrier (in tests with a change in velocity of around 60 km/h).

Thus, it was intended that the deformation experienced by the barrier could distinguish between a vehicle that spread load homogenously around the frontal structure and one that focused the load through small defined longitudinals, the former likely to be much more compatible in-service than the latter. This was successful as shown in Figure 20, below, comparing two light trucks in full width tests at the same speed. However, although these differences can be readily evaluated subjectively, it has proved difficult to define a mathematical algorithm that correlates well with the observed deformations over a wide range of different structures (Johannsen, 2013).

Although the barrier is intended to be more representative of a real car in relation to the stiffness at different vertical levels and at different extents of deformation into the barrier, examining the structure of the barrier shows that it is of uniform structure horizontally along its width (see Figure 21). It will not, therefore, simulate the 'fork effect' of a typical non-homogenous car structure on a FUP.

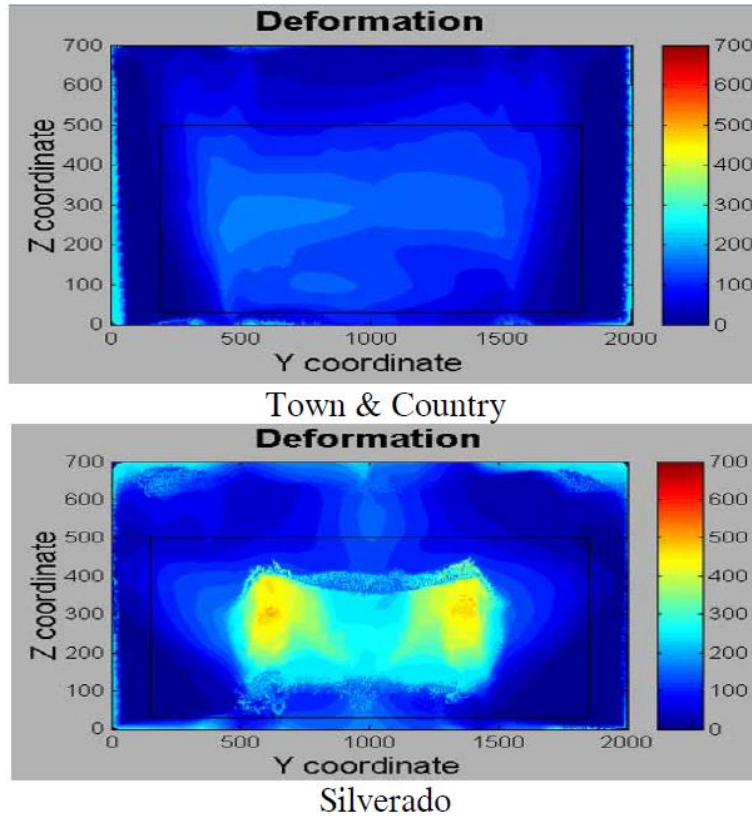

Figure 20: Comparison of deformation on PDB for homogenous and non-homogenous car structures. Source: (Delannoy, Martin, Meyerson, Summers, & Wiacek, 2007)

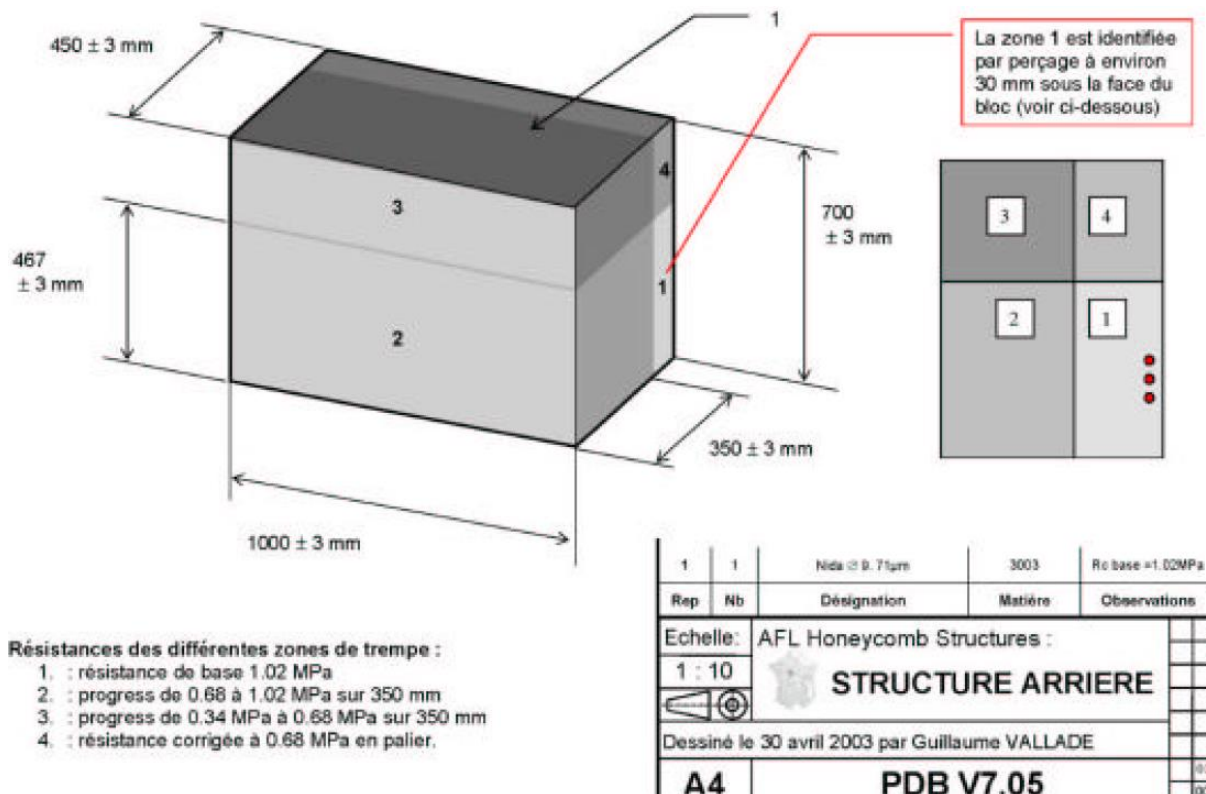

Figure 21: Properties of the PDB. Source (UTAC, 2004)

Figure 22 shows the total forces generated by a PDB, in a calibration test against a rigid wall, will typically be above the average found for a range of passenger cars. The forces generated are also higher than those prescribed for the AE-MDB dynamic calibration corridor, which specifies between 262 kN and 305 kN maximum. Although a corridor for the bottom portion of the PDB only has not been identified, it seems highly likely that the forces applied to the FUP beam will be greater than with the AE-MDB and the risk of bottoming out in tests at Euro NCAP speeds (64 km/h) reduced.

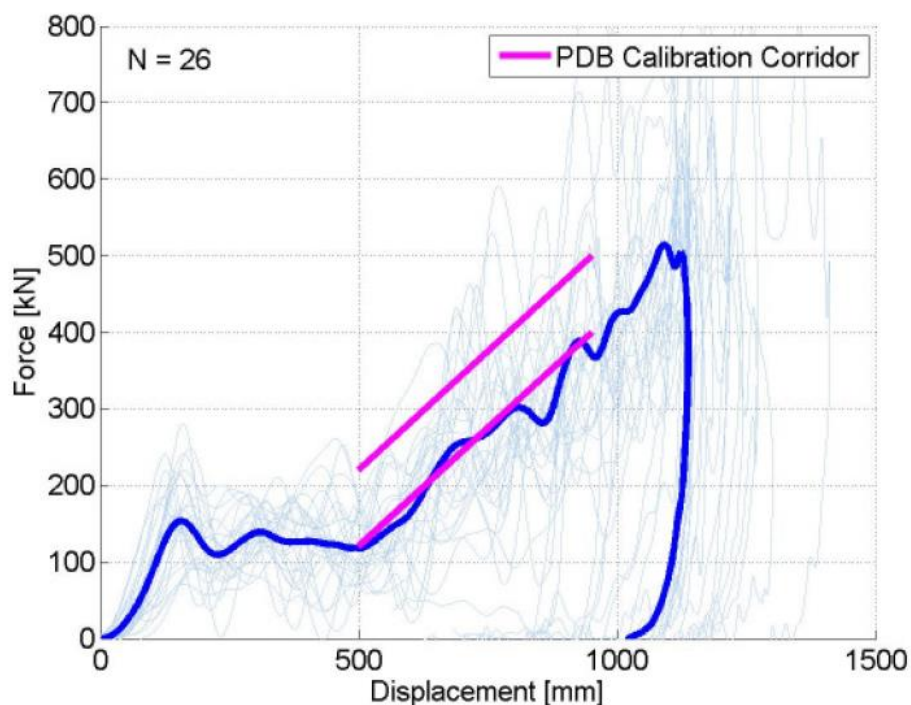

Figure 22: Total forces generated by PDB in comparison to average of 26 cars.
Source: (Uittenbogaard & Vermissen, 2011)

(Schram, Leneman, Zweep, Wisman, & Witteman, 2006) evaluated the use of MPDB in tests of energy absorbing underrun. They found that the results of a MPDB to truck simulation correlated closely with a car to truck simulation at test speeds of up to around 65 km/h but that above that speed there was a divergence in the trolley acceleration compared with the car acceleration. They attributed this to the bottoming out of the PDB at speeds in excess of 65 km/h.

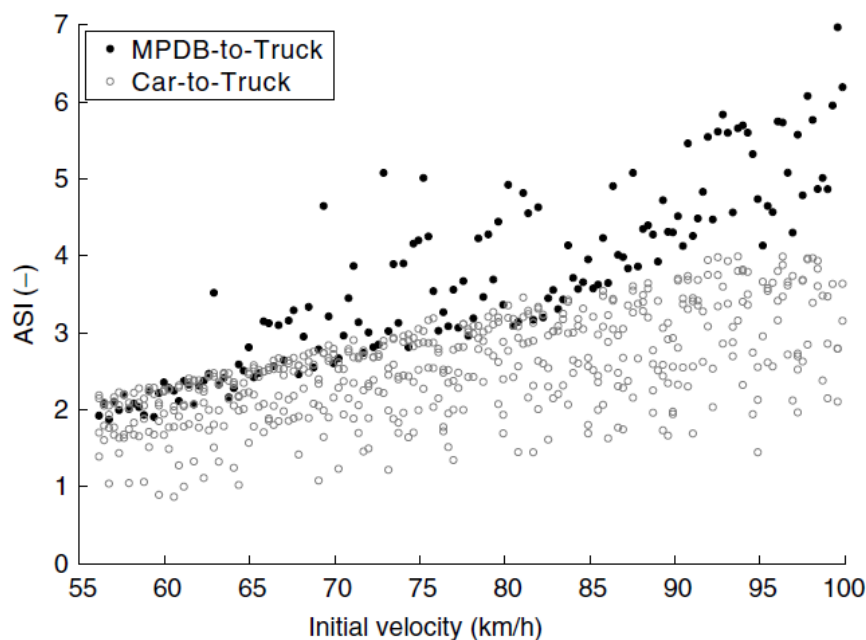

Figure 23: Comparison of acceleration severity index recorded in simulations of MPDB to truck and car to truck crashes. Source: (Schram, Leneman, Zweep, Wismans, & Witteman, 2006).

In theory, if the FUP interacted well and worked perfectly, a 400mm deflection (100kJ energy absorption) should allow a small car (1200kg) to experience the same peak accelerations in a collision at 79 km/h as they would have if colliding with a 'rigid' underrun device at 64 km/h, without any increase in intrusion. Therefore, if the MPDB did not bottom out in a test of a 'rigid' underrun device of the same geometry, then it should not bottom out in the energy absorbing test either because all of the additional energy should be absorbed by the truck.

It can be seen that up to around 65 km/h all MPDB results were in line with the upper end of the range found for real cars. This would be broadly consistent with the above-average stiffness of the PDB in comparison to cars. From 65 km/h to around 85 km/h a proportion of the MPDB results remain in line with the upper end of the range found for cars. However, in the remainder the acceleration experienced by the MPDB was greater than for all of the cars. However, what is unknown is how well the FUP performed in these tests and whether the result for the cars was an equivalence with 64 km/h test. That is, although the MPDB bottomed out and resulted in increased acceleration of the barrier compared to the car, this may be a valid result where poor structural interaction has resulted in intrusion in the passenger car and bottoming out of the barrier. Intrusion into the passenger car will not be reliably modelled by the multi-body technique used.

Although the data is not clear, it is therefore, possible that the MPDB results are accurately identifying tests where the intrusion would be excessive but that this is not being seen in the results of the car.

Further investigation of the behaviour of the PDB would be required to have confidence that it would work correctly in FUP tests at speeds in excess of 64 km/h. However, it already has an advantage over the less stiff AE-MDB, which would be likely to bottom out at lower speeds. If bottoming out was found to be a problem, this could potentially be solved by simply increasing the depth of the rear-most layer of honeycomb. This layer is quite stiff and may not, therefore, require much increased depth.

The MPDB is also relatively tall at 700mm, such that if mounted with a ground clearance of 300mm would give an overall height of 1m, which would be sufficient to interact with chassis rails of almost all existing trucks, such that a risk of gross underrun could be identified in the test. This would also tend to increase the deceleration of the trolley in comparison to a car where the initial interaction would be below the height of the chassis beams.

6.3.6 Passenger car

The use of a full passenger car would allow the use of Anthropometric Test Devices (ATDs, or crash test dummies) to directly measure the probability of injury. Test procedures and injury risk functions are well-defined for passenger car safety. The frontal structure that would interact with the FUP will clearly be realistic for all elements of the structural interaction. However, careful choice of car would be required to ensure it was representative of a wide range of cars, rather than being an unusual outlier in terms of structure or restraints.

The only way that reasonable repeatability could be ensured is to stipulate the exact model of vehicle to be used. This could still allow problems with long term repeatability as models get updated every few years and will eventually be discontinued or changed beyond any level of comparability. Reproducibility can also be problematic because specifications can vary substantially amongst the same model sold in different territories, even within Europe but even more so in a global context.

A clear disadvantage is cost. All test methods will require a FUP system as a test 'consumable' but for quasi-static tests that is the only consumable. For dynamic tests with a deformable barrier, the barrier is a consumable and can cost between around €1,000 and €4,000. However, even a small, low specification car is likely to cost in excess of €10,000 euro, each test would take some portion of the depreciation and maintenance of dummies worth at least €100,000 and would require much more comprehensive data acquisition systems that can cost comparable amounts again. Although such costs are considered acceptable for the approval of passenger cars, in that case the costs are spread across a sales volume that is 1 or 2 orders of magnitude greater than that for commercial vehicles.

6.4 Numerical simulation

The use of numerical simulation in analysis of crash performance has been around for many years and has improved in fidelity considerably. A number of early research initiatives, for example (van Hoof, Puppini, Baldauf, Oakley, & Kayvantash, 2003), have developed techniques with the aim that they will ultimately be capable of direct use within type approval regulations.

In 2006, the rollover strength of bus superstructure (UNECE Regulation 66) became one the first crashworthiness regulation where computer simulation of the test was considered to be an equivalent approval method. R66 rollover of buses allows numerical simulation as a replacement for physical test. A specific annexe was included in the UNECE Regulation to require supporting information for the model and to allow approval authorities to require tests to prove the validity of the model.

UNECE R13/13H were also amended to allow the approval of electronic stability controls via computer simulation or by using hardware in the loop simulation where the real

electronic control module is connected to a simulation such that the computer provides input to the hardware and responds according to the output from it.

Specific requirement in R13H allowing a partial replacement of ESC/BAS tests with simulation. Do 1 test, validate model and then you can use the model to assess compliance of different versions or variants

Directive 371/2010 amended the European type approval framework (Directive 2007/46/EC) to allow virtual testing to replace physical tests more generally for certain regulatory acts. These included the EC Directives on front and rear underrun protection, though not directly the UNECE Regulation equivalents, which implies that an EU approval according to a virtual method may not be accepted by authorities that are signatories of the UNECE 1958 agreement but are not members of the EU.

In each of these case, the simulation is of the defined physical test itself. This allows the vehicle manufacturer to demonstrate approvals more economically. The model can be validated once for a particular type of FUP and then used to demonstrate that the FUP passes the requirements when installed in a range of different vehicle models and variants. However, the approval is still subject to all the limitations of a quasi-static test, it does not allow detailed simulation of the crash situation that FUP is intended to influence.

None of the regulations for which virtual testing is accepted as an alternative, simulate anything as complex as a full car and anthropometric test device, or even the honeycomb barriers used in typical car impact tests. As such, the development of a simulation method for the assessment of FUP that went beyond the quasi-static test would be breaking new ground technically. It may well become feasible but development of an accepted car or barrier model would be more likely to be driven by the economies achievable in passenger car testing.

(Krusper, 2014) described the development of a new numerical simulation method, titled Relative Equivalent Energy Displacement (RED). This appears to primarily offer insight to designers as to how to design crash structures for good compatibility. However, an initial compatibility metric has been developed to compare the performance of a car in a barrier crash test with its performance in a car to car test. It is possible that this method could be adapted to rate the performance of an EA FUP in terms of how similarly a car would behave in such a crash compared to the barrier test it was designed for. However, the method is complex and considerable effort may be required to adapt it. At this stage it has been proposed as an aid to development and not as a rating in any formal scheme.

7 Analysis

In considering how to test energy absorbing front underrun protection back in 2006 (Edwards, et al., 2007) found that a number of potential methods existed but none satisfactorily assessed all of the performance aspects required to ensure good performance in the real world. There has been little substantive research to further develop tests specifically aimed at energy absorbing front underrun protection, though additional research has been undertaken to consider what design features and properties are required for good performance. By contrast, considerable research has been undertaken to develop test procedures that would encourage the development of more compatible passenger cars. This has culminated in proposals to add new tests to both regulatory and consumer testing (e.g. Euro NCAP) regimes.

This review has examined the evidence in relation to the properties that would be desirable in an energy absorbing FUP and has identified several factors that were not considered explicitly during the VC-COMPAT research, such as size and bending stiffness of the FUP cross member and the adverse effects of interaction with other. However, despite the additional research on car compatibility the overall conclusion remains the same; A range of test procedures are potential candidates and each have advantages and disadvantages but none are capable of a complete assessment of all types of FUP that might be encountered. These are summarised below.

- Design requirements: Useful for guaranteeing certain elements of structural interaction, particularly vertical alignment and currently used for that purpose in R93. If used in the control of forces, acceleration, probability of injury etc. it would be likely to stifle innovation and risk unintended consequences.
- Quasi-static test: Simple, inexpensive, repeatable and excellent for the control of bending stiffness of the cross-member. Also, able to control trigger forces, maximum forces and measure energy absorption, though the lack of a dynamic force application will limit accuracy and representativeness. Cannot directly measure probability of injury or represent certain interaction features such as the potential for deflection or angled collisions and is not well suited to assessment of curved FUPs.
- Dynamic test with impact trolley and FUP sub-assembly: Force and energy levels are more representative of real life in a dynamic test, curved FUPs and deflection can be assessed, acceleration can be used as a coarse proxy for probability of injury, different barrier faces have different properties
 - Rigid – allows energy absorption potential of the FUP to be more accurately measured because the trolley will absorb close to zero. However, a FUP designed to absorb energy such that the energy absorbed by the car is the same as in collision with a 'rigid' FUP at 64 km/h, would be tested at a lower speed to compensate for the fact that in the test the 'car' absorbs no energy, thus avoiding excessive forces. Rigid barriers would be relatively poor for assessing structural interaction.
 - AE-MDB – This is a deformable barrier used in Euro NCAP side impact tests and softens the impact such that it is more representative of a real crash and is more useful in assessment of structural interaction. However, it is designed to represent car behaviour in a crash type with a low change in velocity (25 km/h if car and trolley are the same mass). Thus, the barrier

is highly likely to 'bottom out' in a 64 km/h impact with a FUP, acting as a rigid barrier thereafter.

- PDB – The progressive deformable barrier has been used in compatibility research and gets progressively stiffer as it crushes. It has been designed with the aim of identifying stiff components in the front of cars during frontal impacts without bottoming out and would, therefore be expected to be very good for assessing structural interaction but no objective metric has yet been developed. It would not be expected to bottom out in a 64 km/h impact with a 'rigid' FUP. Thus, if an energy absorbing FUP successfully achieved energy equivalence with a 64 km/h rigid test, it would not be expected to bottom out in this either. However, some evidence has been identified to suggest that it might, so this would require further investigation.
- Purpose built – It would be possible to design a deformable barrier that overcame the shortcomings of the others. However, this would incur a substantial development time and cost and, as a lower volume, niche product not necessarily used by the car industry, there would likely be an ongoing cost premium.
- Dynamic test with a real car and crash dummies – this would be the most realistic option but incurs problems with reproducibility in different regions and long term repeatability. The cost is also very high.
- Numerical Simulation – can reduce cost and in theory can allow a wider set of circumstances to be considered. However, to-date it has only been permitted in Type Approval as a direct simulation of the existing test and has only been applied to relatively simple structures or functions. As yet, simulation has not been permitted as a replacement for a sophisticated full scale impact test of a passenger car structure and restraint system.

7.1 Defining the options

The existing UNECE Regulation 93 does not rely only on a single test to prescribe all elements of performance, it combines prescriptive design requirements (e.g. maximum ground clearance 400mm) with a quasi-static test. A similar approach is proposed here to define viable options. A range of realistic permutations are possible, including but not limited to:

- 1) A revised quasi-static test with design requirements prohibiting curved FUP and controlling structural interaction and prevention of underrun
- 2) A dynamic barrier test combined with design requirements to control vertical alignment of structures and prevention of underrun and to define the vehicle structures to be included in a FUP sub-assembly. This test could employ different barrier faces:
 - a) AE-MDB
 - b) PDB
 - c) Purpose built barrier
- 3) As 2)a or 2)b above but adding a quasi-static test to better assess the car 'fork effect' and the bending stiffness of the FUP cross member

In order to enhance consideration of the options, each individual test and the main permutations of multiple tests were analysed in a semi-objective rating scheme by scoring each test between 0 and 10 against each of the parameters considered likely to be important. In this way each individual rating is subjective but the total for each test is objective. This should be considered an aide to the evaluation of each option rather than a fully scientific analysis and the matrix is shown in full in Appendix A.

From this initial matrix, three feasible options have been selected for further definition:

- Quasi-static tests combined with design requirement
- Mobile Progressive Deformable Barrier test combined with design requirements
- Purpose designed deformable barrier test combined with design requirements

A full cost benefit analysis, informed by test results on prototype devices, would be required to fully inform a decision as to which approach was the most appropriate considering all of the objectives of the type approval system. However, the initial scoring suggests that an MPDB based approach would offer substantial safety and innovation advantages over a quasi-static based assessment but would cost considerably more and require more complex development. A purpose built barrier would only be necessary if identified risks of the PDB approach did indeed prove to be problematic when assessed with representative prototype devices.

7.1.1 Quasi-Static assessment

It is proposed that a quasi-static assessment should only be considered for a 'straight' FUPS. This can be defined according to the geometry explored in (Knight, 2014) based on the existing requirements of R93. This would require the FUP to be essentially straight across the front of the vehicle with the exception of the outermost 200mm at each side of the vehicle. This could be implemented by a design restriction that:

"The radius of curvature of the FUP cross-member in the horizontal plane shall be greater than [10]metres at all points except for the outermost 200mm at each side"

Combined with manoeuvrability constraints this means that the FUP can be positioned no more than around 450mm further forward than the front of an existing vehicle. This does not necessarily limit the length of the vehicle provided the structure ahead of the FUP and around the area it will deform into does not interfere with either the structural interaction between the FUP and the vehicle or the energy absorbed by the FUP. It is proposed that this is controlled by a further design requirement as follows:

"The FUPD shall be so fitted to the vehicle that the horizontal distance measured in the rearward direction from a transverse plane passing through the leading edge of the foremost stiff structure to the front of the FUPD does not exceed 400mm diminished by the recorded deformation measured at any of the points where the test forces have been applied during the type approval of the FUPD"

"Stiff structures will be identified by the type approval authority but as a minimum shall include the main chassis rails, any structural sub-frames, steering mechanisms, attachments to enable vehicle towing, engine or cooling pack".

These requirements should also prevent the potential for gross underrun under a higher structure.

The vertical alignment of the FUP and the passenger car should also be controlled by a design requirement but amended to overcome the existing problems where standardised FUPs end up too low.

"Structure constituting the FUP cross member shall cover 100% of the area defined by the overall width of the vehicle, measured to the outer edge of the tyres of the front axle, less a maximum of 100mm at each side, and a height from the ground of between 400 and 510mm. At least [70]% of the area should be occupied by the FUP cross-member at a height of between 330mm and 580 mm from the ground. "

In this way, the truck would be guaranteed to have structure across the 'Part 581' zone defined for US compatibility requirements and for a large part of the 'common interaction zone' defined by the FIMCAR project. The FUP cross-member must be at least 175mm tall, an increase over the current minimum of 120mm. This would be expected to improve structural interaction and increase the force applied to energy absorbers. Flexibility over the exact ground clearance is still permitted but manufacturers would require a taller FUP cross-member if they wished to install the device with a ground clearance less than 330mm.

Increasing the cross-member height and ensuring no other stiff structures interact with the car will increase the forces applied directly to the cross Member. The loads are transmitted to the chassis via the regulatory point P2, effectively where typically the cross member is supported by an upright. Thus, to maintain behaviour that is essentially 'rigid' until such point as the car is deforming properly and has triggered restraints, it may be necessary to increase the initial force level in comparison to the force currently used in R93 (160 kN). However, the research also suggested that the car would be substantially deformed by the time a total force of between 150 kN and 200kN was reached based on load cell wall measurements. The larger FUP will still interact with less than all of the front, which would tend to suggest lower forces than that range. An initial compromise would be to aim for the middle of the range but this should be validated by test work. To minimise the risk of passenger cell deformation occurring before the FUP energy absorption is complete, even in small cars, the maximum force used in the test should be less than 300kN.

This requirement produces a corridor for force deflection characteristics as shown below.

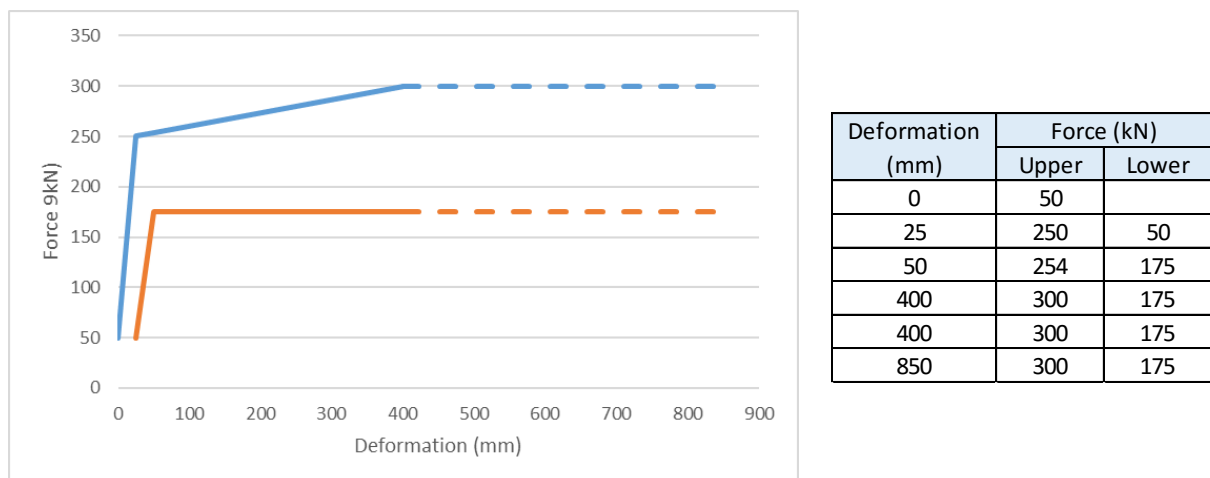

Figure 24: Proposed force deflection corridor for test point P2 in a quasi static test.

It should be noted that an existing R93 FUP can potentially deform up to 400mm. For deformations beyond this, the exact requirements will depend on the length extension selected by the manufacturer (hence dashed lines in the corridor). If taking advantage of the furthest forward permitted FUP position of 450mm, then the total deformation could be up to 850mm.

The actual measured force deflection curve shall be permitted to fall outside the corridor only once the minimum defined energy (E) has been absorbed.

The minimum quantity of energy shall be defined in relation to the position of the FUP ahead of the normal front of the vehicle. For the purposes of the minimum it is assumed, based on VC COMPAT research that only 200mm of the 400mm permitted under the front of an existing truck is usable for energy absorption. For a maximum length extension of FUP this would dictate a deformation length of 650mm. It is proposed in this scenario that a minimum of [140] kJ energy absorption be proposed. This could be achieved by 600mm of deformation at a constant force of 230kN or by a linearly increasing force between 175kN and 300kN over 600mm.

When different front extensions ($x < 0.45\text{m}$) are considered, then the energy requirement should be based on the following formula

$$E = 230 * (x + 0.15)$$

As per current regulations, if symmetry in structures can be demonstrated then it will not be necessary to test both points P2.

Finally, it is also necessary to control the stiffness of the cross-member. This will involve tests at points P1 and P3. The evidence suggests performance will be improved by increasing the stiffness of the cross-member so it is proposed that the test load is increased to [150kN] and the deformation at this point limited to [50mm]. Tests at these points should be undertaken sequentially before the test at point P2.

7.1.2 MPDB based assessment

The lack of an existing defined structural interaction metric based on deformation damage of a PDB means that the design requirements relating to vertical alignment and interaction with non-FUP components and gross underrun shall be the same in this procedure as proposed above in the quasi-static based assessment. However, the procedure would not be restricted to straight FUPs only. Thus the design requirements would be:

"The FUPD shall be so fitted to the vehicle that the horizontal distance measured in the rearward direction from a transverse plane passing through the leading edge of the foremost stiff structure to the front of the FUPD does not exceed 400mm diminished by the recorded deformation measured at any of the points where the test forces have been applied during the type approval of the FUPD"

"Stiff structures will be identified by the type approval authority but as a minimum shall include the main chassis rails, any structural sub-frames, steering mechanisms, attachments to enable vehicle towing, engine or cooling pack".

"Structure constituting the FUP cross member shall cover 100% of the area defined by the overall width of the vehicle, measured to the outer edge of the tyres of the front axle, less a maximum of 100mm at each side, and a height from the ground of between

400 and 510mm. At least [70]% of the area should be occupied by the FUP cross-member at a height of between 330mm and 580 mm from the ground. "

It is proposed that the FUP is rigidly mounted to a concrete block (>70 tonnes) in a manner representative of its fitment on a real truck, including a length ([>1m]) of the chassis rails that it is mounted to in real service.

The mobile trolley and PDB used as a car substitute shall be designed as prescribed by the FIMCAR proposed MPDB test protocol (Uittenbogaard & Vermissen, 2011) sections 2.1, 2.2 and 7.1. Thus the trolley mass shall be 1500kg and the PDB specification version 8.

The test speed for energy absorbing FUP will depend on the length extension considered and, therefore, the deformation length available. The proposal is shown in Table 3, below.

Table 3: Proposed test speeds based on length

Length extension (mm)	Deformation length available (mm)	Proposed test speed (km/h)
0-200	200-400	70
201-400	400-600	80
401-600	600-800	85
601-800	800-1000	90

The speeds proposed are at the low end of what was predicted as feasible in Figure 15 because the FUP will be a fixed installation and not a truck that is free to move. This increases the energy the FUP must absorb for a given speed compared to a real situation where some of the energy will be used to change the kinetic energy (speed) of the truck.

It is proposed that the overlap is set at 50% of the width of a car, which is consistent with the conditions the PDB was designed for. However, in this case a reference car width must be defined because no actual car will be tested. It is, therefore proposed that the width of PDB that will align with the truck shall be 0.9m, which is equivalent to 50% of a car 1.8m wide. This shall be measured against the width to the outer edge of the tyres and not to the width of the FUP (which may be 100mm in-board of this point).

The limit value for the performance of the FUP will need further consideration based on the results of tests with prototype devices ahead of introduction. At this stage it is proposed that it is based on an acceleration severity index value of [2.5].

Any remaining conditions and controls (e.g. speed and mass tolerance, data acquisition requirements etc.) should be based on existing test procedures such as the Euro NCAP side impact test or UNECE R95.

7.1.3 Purpose defined barrier

This option only requires consideration if tests with prototypes reveal that the PDB test is insufficient to promote good cross-member stiffness or if the PDB is found to bottom out in cases where real vehicles would still offer good protection (considering both acceleration and intrusion).

In such a case, the basic procedure is likely to remain the same, it is just the properties of the deformable barrier face that would change. These cannot be defined at this stage because not enough is known about the problems that might be experienced with designs not yet tested.

7.2 Potential benefits

The potential benefits of the improvements to front underrun protection defined in this report can be estimated from the data regarding the number of casualties killed or seriously injured in head on collisions, the evidence concerning the closing speeds typically involved in those collisions, the predicted ability of increased energy absorption to make higher speed collisions equivalent in energy terms to car crashes at Euro NCAP speeds, and the ability of manufacturers to maximise the deformation length available within the additional length extension they might select.

Most European Member States define a casualty prevention value, a monetary value to represent the economic losses associated with road casualties of different severities. In 2015 (Hynd, et al., 2015) studied these values and used weighted averages to come up with a value representative of the EU as a whole:

- Fatal: €1,564,503
- Serious: €231,278

These values per casualty have been used here to provide an indication of the monetary representation of the casualty reduction benefit that could be achieved by improved front underrun protection. The results are shown in Table 4, below.

Table 4: Summary of potential casualty reduction benefits of improved FUP, given a range of length increases.

Length increase (mm)	Estimate boundary	Energy absorption length (mm)	Crash speeds in scope (km/h)	Fatalities in head on collisions with HGVs (n=670)		Serious injuries in head on collision with HGVs (n=1500)		Annual casualty prevention value (€Millions) at 100%
				% in scope	Num in scope	% in scope	Num in scope	
200	Lower	200	70	5%	34	40%	600	€ 191
	Upper	400	90	15%	101	55%	825	€ 348
400	Lower	400	75	6%	40	45%	675	€ 219
	Upper	600	95	17%	114	60%	900	€ 386
600	Lower	600	85	8%	54	50%	750	€ 257
	Upper	800	100	20%	134	60%	900	€ 418
800	Lower	800	90	10%	67	55%	825	€ 296
	Upper	1000	105	27%	181	65%	975	€ 509

It should be noted that this assumes fitment to all heavy goods vehicles in Europe. Increased length is expected to be used mainly on vehicles operating mainly outside of urban areas, which is where most crashes relevant to front underrun protection occur. However, the actual benefits will depend on the actual market penetration of the equipped vehicles in the specific areas these crashes occur. These figures should, therefore be considered a maximum.

7.3 Proposed validation programme.

To prove out these proposed test procedures to allow more confidence in the findings of this desk-based review and to refine any proposed limit values, may require a considerable test programme. The first stage of such a programme would be to design and build prototype FUPs that would just meet the minimum requirements proposed in

each scenario (straight FUP up to 450mm forward or curved FUP up to 800mm forward of existing front). A range of factors could be investigated and/or validated:

- A comparison of the occupant injury in a collision between a baseline R93 compliant FUP and a typical passenger car at 64 km/h and the different proposed FUPs at speeds of up to 90 km/h (constructed in compliance with the proposals above). Aim is to validate the expected injury benefit, validate that the proposed FUP trigger forces are appropriate to both provide a stable initial platform for the car to deform against and then begin to absorb energy before forces rise to a level likely to cause occupant compartment deformation. It should also provide a baseline for comparison with the simplified test results.
- Evaluation of the same FUP devices using the proposed quasi-static based assessment and the MPDB based assessment. Consideration of how well the results correlate with the actual injury measures. For example, if the full scale tests show that a particular FUP design tested at 80 km/h achieves the same injury outcome as the same car colliding with an R93 FUP at 64 km/h then the quasi-static test should be 'passed'. In this case it would be seen to be a 'good' test. However, if it failed an FUP that got good results in a full scale test or 'passed' a FUP that scored badly in the full scale test then it would suggest that this is a poor test to use.
- Any repetition necessary to 'tune' the results of the tests to the 'real world' injury measures.
- Investigation of the performance of energy absorbing FUPs in angled collisions to consider whether additional tests are required to ensure good performance in imperfect real world collisions.
- Investigation of the compatibility effects with curved FUPS; 'point' loading in full overlap centred tests and deflection in low overlap. Are additional tests required to ensure appropriate requirements?

The above programme could be undertaken by physical testing or numerical simulation. Numerical simulation would likely be more cost effective and allow a wider exploration of the variables but it would be important to consider carefully whether to use Finite element simulation, multi-body simulation or a combination of the two. Validation of the models in at least one relevant physical test would also be very important.

Both the test methods proposed would be expected to encourage FUP designs that capture a significant proportion of the potential casualty benefits identified in section 7.2 above. However, it may well be that the results of the validation will show that one test will be more effective than the other in promoting designs that work in the real world and thus implementing one would capture a greater proportion of the available casualty benefit. In the latter case, this result would need to be factored into any impact assessment to quantify whether the additional benefits of the test outweighed any additional costs.

8 Conclusions

- 1) Head on crashes between cars and trucks are a very severe type of crash involving high relative speeds and a high risk of fatality. Front underrun protection (FUP) was introduced to try to reduce the risks of these crashes. Most current devices are built for compliance with existing regulation and few offer as standard an integrated energy absorbing system. There is evidence to suggest that current devices are not reducing deaths and serious injuries in the way that was expected when they were introduced. The exact reasons for this cannot be proven but the lack of energy absorption combined with evidence of poor structural interaction in some cases could well be explanatory factors.
- 2) Directive 2015/719 to increase the length of HGVs in defined circumstances provides an opportunity to redesign Front underrun protection to improve performance in both those areas. This review has identified the desirable properties for front underrun protection on extended length trucks and assessed the ability of different test methods to ensure the devices do possess those properties.
- 3) Good structural interaction is a pre-requisite of effective energy absorption and effective casualty reduction. The proposed test methods would ensure an improvement in that interaction. The benefits of energy absorption itself will depend on the length increase chosen by the manufacturer. A length increase of 400-600mm could make crashes with closing speed of up to around 75km/h to 100 km/h survivable, depending on a range of variable. If this performance level was standard fitment in the fleet then it could prevent 40 – 134 deaths and 675 to 900 serious injuries in the EU, valued at between around €220million and €420 million.
- 4) Three feasible policy options were identified for the implementation of a test procedure to define these new performance levels. They involve combining design restrictive criteria with assessments based on:
 - a) Quasi-static testing
 - b) A Mobile Progressive Deformable Barrier (MPDB) test
 - c) A mobile test with a purpose designed barrier face
- 5) The proposals are soundly backed by theory and evidence adapted from tests on standard length vehicles. However, a substantial validation test programme would be required to prove the effectiveness of the tests in promoting good real world performance, to refine the selection of limit values and to inform cost benefit analyses used to help select the final procedure.
- 6) An initial, semi-objective, scoring of the options suggests that an MPDB based approach would offer substantial safety and innovation advantages over a quasi-static based assessment but would cost considerably more and require more complex development. A purpose built barrier would only be necessary if identified risks of the PDB approach did indeed prove to be problematic when assessed with representative prototype devices.
- 7) Numerical simulation may still be acceptable for type approval as an alternative to the physical test procedures defined. However, if additional validation may be required if the dynamic tests were selected because it is a much more complex test than those structural tests that 2007/46/EC permits to be replaced by simulation.

9 References

- Adolph, T., Ott, J., Eickhoff, B., & Johannsen, H. (2015). *What is the benefit of the frontal mobile barrier test procedure*. Gothenburg: Proceedings of the 24th international technical conference on the enhanced safety of vehicles.
- Anderson, J. (2003). *Inventory of current underrun devices*. Deliverable 1.6 of the VC-Compat project.
- Bumjin, K., Hyunwoo, K., & Dongho, P. (2013). *Research on the AE-MDB CAE Analysis for the improved Euro NCAP side impact test procedure*. Seoul: Proceedings of the 23rd International technical conference on the enhanced safety of vehicles.
- Chislett, & Robinson. (2010). *Investigating the real world effectiveness of introducing mandatory fitment of front underrun protection to heavy goods vehicles*. Wokingham: TRL Limited.
- Delannoy, P., Martin, T., Meyerson, S., Summers, L., & Wiacek, C. (2007). *PDB Barrier face evaluation by DCSR and NHTSA's joint research program*. Proceedings of the 20th International Technical conference on the enhanced safety of vehicles, US DOT.
- Draheim, A., Hurnall, J., Case, M., & Del Beato, J. (2005). *Structural energy absorption trends in NCAP crashed vehicles*. Proceedings of the enhanced safety of vehicles conference 05-317.
- Duque, Damm, Grover, & de Co. (2006). *Definition of the bullet and target device and supporting test reports*. VC Compat.
- Edwards, de Co, van der Zweep, Thomson, Damm, Martin, . . . Hashemi. (2007). *VC Compat Final Technical Report*. VC COMpat.
- Edwards, M. (2009). *Development of a high deceleration full width frontal impact test for Europe*. Proceedings of the 21st International technical conference on the enhanced safety of vehicles.
- Edwards, M., Cuerden, R., & Davies, H. (2007). Current status of the full width deformable barrier test. *Paper number 07-0088, Proceedings of the 20th ESV conference*. NHTSA.
- Eggers, A., Schwedhelm, H., Zander, O., Cordero Izquierdo, R., Garcia Polanco, J., Paralikas, J., . . . Jacob, C. (2013). *Virtual Testing based type approval procedures for the assessment of pedestrian protection developed within the EU project IMVITER*. Proceedings of the 23rd International technical conference on the enhanced safety of vehicles, US DOT.
- Enomoto, H., & Akiyama, K. (2005). Development of safety concept trucks; ASV concept L and ASV concept C. *Proceedings of the 19th Enhanced Safety of Vehicles conference*. Washington DC: NHTSA.
- Euro NCAP. (2013). *Technical Bulletin 014 AE-MDB Specification*. Brussels: www.euroncap.com.
- Euro NCAP. (2015). *Side Impact Mobile Deformable Barrier Testing Protocol Version 7.1.1*. Brussels: www.euroncap.com.
- European Road Safety Observatory. (2015). *Traffic Safety Basic Facts 2015: Heavy Goods Vehicles and Buses*. Brussels: www.erso.eu.

- Forsman, L. (2002). *Compatibility in Truck to Car Frontal Impacts*. Delft, The Netherlands, Europe, June 16-20: 7th International Symposium on Heavy Vehicle Weights and Dimensions.
- Framby, J., & Lantz, D. (2010). *Robustness and Reliability of Front Underrun Protection Systems*. Gothenburg: Chalmers University.
- Gabauer, D., & Gabler, H. (Undated). *Evaluation of the Acceleration Severity Index Threshold Values Utilising Event Data Recorder Technology*. Glassboro: Rowan University.
- Gwehenberger, J., Bende, J., Knight, I., & Klootwijk, C. (2004). *Collection of existing in-depth accident cases and prediction of benefit of having front and rear underrun protection*. Deliverable D05 of the EU funded VC-COMPAT project.
- Huibers, J., & de Beer, E. (2001). *Current front stiffness of European vehicles with regard to compatibility*. Proceedings of the 17th International Technical conference on the enhanced safety of vehicles.
- Hynd, D., McCarthy, M., Carroll, J., Seidl, M., Edwards, M., Visvikis, C., . . . Stevens, A. (2015). *Benefit and feasibility of new technologies and unregulated measures in the fields of vehicle occupant safety and protection of vulnerable road users*. Brussels: The EU Bookshop.
- Johannsen, H. (2013). *FIMCAR Summary report*. Berlin: Output of the EU funded FIMCAR project.
- Knight, I. (2014). *Investigating the extent to which UNECE R93 constrains the ability of Europe to permit longer trucks to improve safety and environmental performance*. Brussels: Transport & Environment.
- Krusper, A. (2014). *Structural Interaction between vehicles: An investigation of Crash Compatibility between Cars and Heavy Goods Vehicles*. Gothenburg: Chalmers University of Technology.
- Lambert, J., & Rechnitzer, G. (2002). *Review of Truck Safety - Stage 1: Frontal Side and Rear underrun protection*. Monash University Accident Research Centre.
- Matheis, R., & Welfers, T. (2011). *Concept design of a crash management system for heavy goods vehicles*. Aachen: FKA.
- Nilsson, L., & Forsberg, J. (n.d.). *Crash Zone Concept - A conceptual study of energy absorbing frontal under-run devices*. Linköping University.
- Robinson, B., Knight, I., Robinson, T., Barlow, T., & McCrae, I. (2010). *Safer Aerodynamic Frontal Structures for trucks: final report*. Wokingham: TRL Limited.
- Saunders, J., Craig, M., & Parent, D. (2012). *Moving deformable barrier test procedure for evaluating small overlap/oblique crashes*. SAE International doi:10.4271/2012-01-0577.
- Schram, Leneman, Zweep, v. d., Wismans, & Witteman. (2006). *Assessment criteria for assessing energy absorbing Front Underrun Protection on Trucks*. Athens, Greece: International Journal of Crashworthiness.
- Sturt, R., & Fell, C. (2009). *The relationship of injury risk to accident severity in impacts with roadside barriers*. The international Journal of Crashworthiness, Vol 14, no 2,165-172.

- Thompson, R., Krusper, A., O'Brien, S., & Adolph, T. (2012). *The influence of FIMCAR test procedures on other impact types*. Brussels: Deliverable D6.4 of the FIMCAR project.
- Uittenbogaard, J., & Vermissen, T. (2011). *Test protocol - Mobile progressive deformable barrier*. Deliverable D4.1 of the EU funded FIMCAR project.
- UNECE. (1994, February). Regulation no 93: Uniform Provisions concerning the approval of Front underrun protective devices. Geneva: UNECE.
- UTAC. (2004). *Self and Partner Protection Test and Assessment Protocol based on current R94 and PDB barrier*. Brussels: European Enhanced Vehicle Safety Committee.
- van Hoof, J., Puppini, R., Baldauf, H., Oakley, C., & Kayvantash, K. (2003). *Adviser: A software tool for evaluation of numerical models in crash safety analysis*. Proceedings of the 18th international technical conference on the enhanced safety of vehicles.

Appendix A Semi-Objective Scoring Matrix

Variable		Design prescriptions	Quasi-static test	MRB	AE-MDB	M-PDB	Purpose designed MDB	Full scale car	Quasi static plus curve limiting design prescription	AE-MDB + SI design prescription + fork quasi static	MPDB + SI Design restrictions	MPDB + SI Design + Fork Quasi-static	Purpose designed MDB + SI design interaction
Speed	90	0	6	6	2	6	10	10	6	2	6	6	10
	75	0	6	6	4	8	10	10	6	4	8	8	10
	64	0	6	6	6	10	10	10	6	6	10	10	10
Overlap	Low	2	6	9	10	10	10	10	6	10	10	10	10
	Offset	2	6	9	10	10	10	10	6	10	10	10	10
	Full	2	6	9	10	10	10	10	6	10	10	10	10
Angle	Perpendicular impact	0	6	10	10	10	10	10	6	10	10	10	10
	Angled impact/curved FUP	0	0	10	10	10	10	10	0	10	10	10	10
Probability of injury	ATD	0	0	0	0	0	0	10	0	0	0	0	0
	Proxy	0	0	5	6	7	6	10	0	6	7	7	7
Structural Interaction	Vertical alignment	10	3	3	7	8	7	8	10	10	10	10	10
	Horizontal: Car Fork	2	9	0	3	3	8	9	9	10	3	10	8
	Horizontal: Truck point of curve	6	0	0	7	8	8	8	6	7	8	8	8
	Horizontal: Truck deflection	4	0	0	7	7	8	9	4	7	7	7	8
Stiffness	Deformation phasing: Trigger force	0	6	8	7	7	8	8	6	7	7	7	8
	Interaction with other components	7	2	2	7	8	8	8	7	7	8	8	8
Energy absorption		0	6	10	1	2	1	1	6	1	2	2	1
Prevention of Underrun		8	8	8	8	9	10	10	8	8	9	9	10
Repeatability/reproducibility		9	10	8	8	8	8	0	9	8	8	8	8
Cost		10	9	8	7	6	5	0	9	6	6	5	5
Encouraging innovation		0	5	7	8	8	9	8	2	8	8	8	9
Total		62	100	124	138	155	166	169	118	147	157	163	170
Total (%)		30%	48%	59%	66%	74%	79%	80%	56%	70%	75%	78%	81%